

Advanox™

ADVANCED OXIDATION

INSTALLATION MANUAL

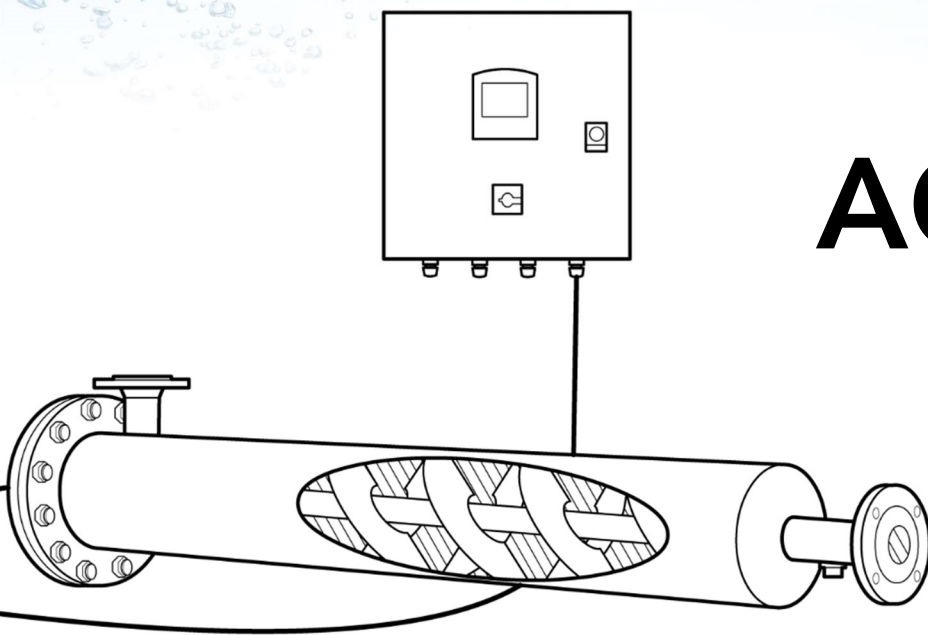

AOP Pool

150
250
500



1 System information

Devices of this series are available in different variants.

These instructions only apply to the supplied device and/or series. The device is uniquely identified via the serial number.

Declaration of Conformity

The product is in accordance with the:

Low Voltage Directive	2014/35/EU	[LVD]
Electromagnetic Compatibility Directive	2014/30/EU	[EMC]
Machinery Directive	2014/42/EC	

If desired, the statement can be provided on request.

Performance

The UV-C dose delivered by this device has been verified using proprietary software. Its performance as well as the geometry of the reactor have been designed with reference to a range of certified UV disinfection systems.

2 Introduction

Read this manual carefully before installing or using this appliance. This manual is a part of the device: keep it at hand for further reference.

This device complies with the relevant European directives and additional national rules. Conformity is indicated by means of a CE marking.

2.1 Warning



UV-C light damages your skin and the retina of your eyes, therefore avoid direct and indirect radiation.

If the UV-C lamp hours have expired, the UV dose of the device is no longer guaranteed!

2.2 Advanced Oxidation Processes with UV

This product uses ultraviolet (UV) light in combination with advanced oxidation processes (AOP) to break down microscopic chemicals in water. AOP use highly reactive hydroxyl (OH) radicals to break down micropollutants. In AOP with UV (UV-AOP) an oxidizer is split by the UV light and the OH radicals are either formed directly or indirectly. This product uses UV-C light which is an electromagnetic radiation with a wavelength between 200 and 290 nanometers. The used oxidizer is hydrogen peroxide (H₂O₂), which is split into two OH radicals.

The produced OH radicals can break chemical bonds in the micropollutants, and as one or multiple bonds are broken the structure of the micropollutant changes and it becomes a different compound, a so called transformation product. The transformation products are generally less harmful and more biodegradable than the original micropollutant.

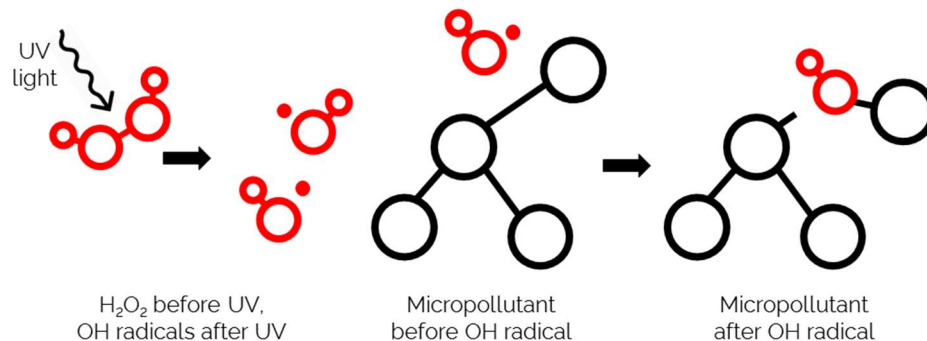

The UV dose needed for UV-AOP falls in the range of 5000-20000 J/m² combined with the oxidizer to produce the OH radicals. The amount of oxidizer needed depends on the amount of micropollutants and the oxidizer used. When using H₂O₂, a concentration of 5-30 ppm is needed. If the oxidation effect is not enough, more OH radicals can be produced either by increasing the UV dose or the amount of oxidizer. Because of the high UV dose the water is also completely disinfected during UV-AOP.

2.3 Warranty conditions

The metal union conditions apply to the devices supplied by van Remmen UV technique. This warranty expires if:

- The device is incorrectly installed, used and/or maintained.
- Defects have occurred due to accident, misuse, unit modifications made by unauthorized personnel, transport damage, power failure and/or damage resulting from use other than for which the device was originally designed.
- Use of unofficial replacement parts.
- Defects and malfunctions due to water leakage.
- No device data has been provided in the event of a failure, failure of a UV-C lamp. It should be possible for the manufacturer to investigate the failure. For this reason, the manufacturer can ask for information regarding the maintenance intervals of the different wear parts.

2.3.1 Wear parts

There are a number of parts that are exposed to UV-C radiation. UV-C reduces the properties of the materials, so that the safety and performance of the device is no longer guaranteed. For this reason, certain parts must be replaced per set replacement period.

The device contains parts that are subject to wear. These parts are not covered by the warranty, unless it can be demonstrated that the parts have failed for another reason.

See section [19. Replacement parts \(p. 25\)](#) for more insight into the replacement interval of different parts.

2.4 Packaging, transport and storage

The delivery consists of two packages that together provide all the components to install and run the device.

The device is packed with the utmost care to ensure that it arrives without any damage. Damage may have occurred during transport. Therefore, check the packaging and the product for damage. Report any damage to the carrier and to your supplier.

Store the device and the loose components in a dry and dust-free place that is sufficiently ventilated. Do not place products in direct sunlight and keep the different parts in the original packaging for as long as possible before installation.

Transport

Pay attention to safety during loading/unloading and moving the device. Think of risks such as dropping and unintentional shifting of the delivered products. Only use means that are suitable for moving the device. Take into account the weight and centre of gravity of the device.

2.5 Check received parts

The appliance contains the following parts that must be checked before installation. The device contains the following components:

- Assembled reactor chamber.
- Control unit for controlling UV-C lamp.
- Set of gloves, for maintenance and assembly work.
- Instruction manual.

3 Table of contents

1	System information.....	2
2	Introduction.....	2
2.1	Warning	2
2.2	Advanced Oxidation Processes with UV	2
2.3	Warranty conditions	3
2.3.1	Wear parts	3
2.4	Packaging, transport and storage.....	4
2.5	Check received parts	4
3	Table of contents.....	5
4	Glossary	7
5	Product introduction	7
6	Dimensions.....	8
6.1	Reactor chamber	8
6.2	Control unit	8
7	Technical specifications	9
8	Device requirements	9
8.1	Requirements on the installer.....	9
8.2	Requirements on the environment	9
8.3	Requirements on the electrical installation	10
9	Safety measures & regulations	10
10	Environment & Scrapping.....	11
11	Logbook.....	11
12	Optional Temperature protection.....	12
13	Control unit	12
13.1	Dimensions	13
13.2	Mounting	13
13.3	Alarm contacts	13
13.4	Installation.....	13
13.5	Electrical connection.....	14
13.5.1	Terminal strip	14
13.6	Use	14
13.7	Maintenance	14
13.8	Failure.....	14
14	Reactor chamber	15
14.1	Installation.....	15
14.1.1	Pressure test.....	16
14.2	Use	16
14.3	Maintenance	16

14.3.1	Cleaning.....	16
15	Commissioning	17
15.1	Start-up device.....	17
15.2	Operation	17
16	UV-C lamp	18
16.1	Lamp connector	18
16.2	Disassembly	19
16.3	Assembly	20
16.4	Resetting UV-C lamp hours.....	21
17	Quartz sleeve.....	21
17.1	Disassembly	21
17.2	Assembly	22
18	Touch screen interface	23
18.1	Info.....	23
18.2	Login	24
18.3	Language.....	24
18.4	Lamps	24
18.5	Settings.....	24
18.6	Alarm	24
19	Replacement parts.....	25
19.1	Parts list.....	25

4 Glossary

Flow	Is a physical quantity for a flowing medium, expressed as the quantity of a liquid per unit of time.
Dose	The dose refers to the radiation intensity generated by the UV-C lamps versus the residence time of the product. Dose has the unit of measure J/m^2 .
Pre Alarm	Operational status where the value of one of the device's control parameters is in the direction of the Main Alarm value.
Main Alarm	Operational status where the value of one of the control parameters of the device exceeds the limit, UV-C dose is no longer guaranteed.

5 Product introduction

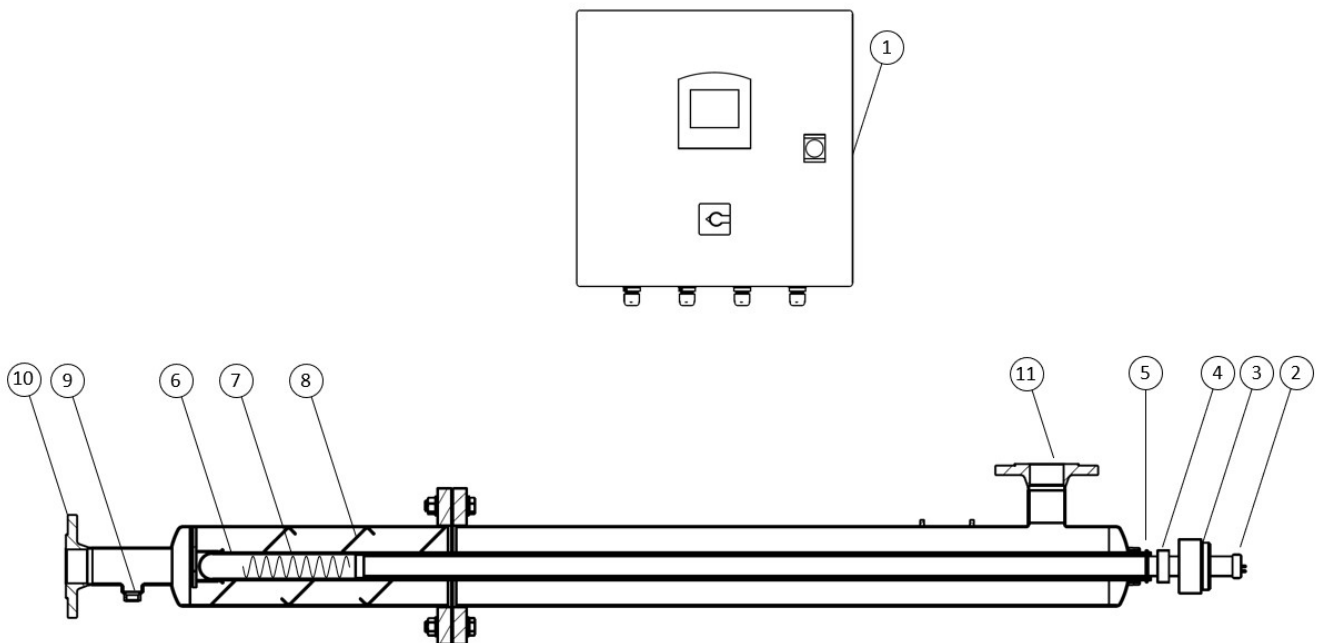

Item	Description	Function
1	Control unit	Management of the UV-C lamp and control of the UV-AOP process
2	UV-C lamp	Generation of light with a wavelength of 254nm
3	Reactor coupling	Fixing the locking sleeve
4	Locking sleeve	Fixing the O-ring, sealing the quartz sleeve
5	O-ring quartz sleeve	Quartz sleeve seal
6	Quartz sleeve	Housing and protection for the UV-C lamp
7	Safety spring	Fixing the UV-C lamp in the quartz sleeve
8	Flow mixer	Elements for evenly mixing H_2O_2 with the supplied water
9	Dosing pump connection	Festo fitting for connecting the H_2O_2 dosing pump
10	Inlet flange	Flange connection for incoming water
11	Outlet flange	Flange connection for outgoing water

6 Dimensions

6.1 Reactor chamber

The dimensions of the reactor chamber are dependent on the type of device.

Connections

DN50 flanged connection

Installation space (E)

is the minimum required space to install and maintain the device calculated as being twice the length of the reactor

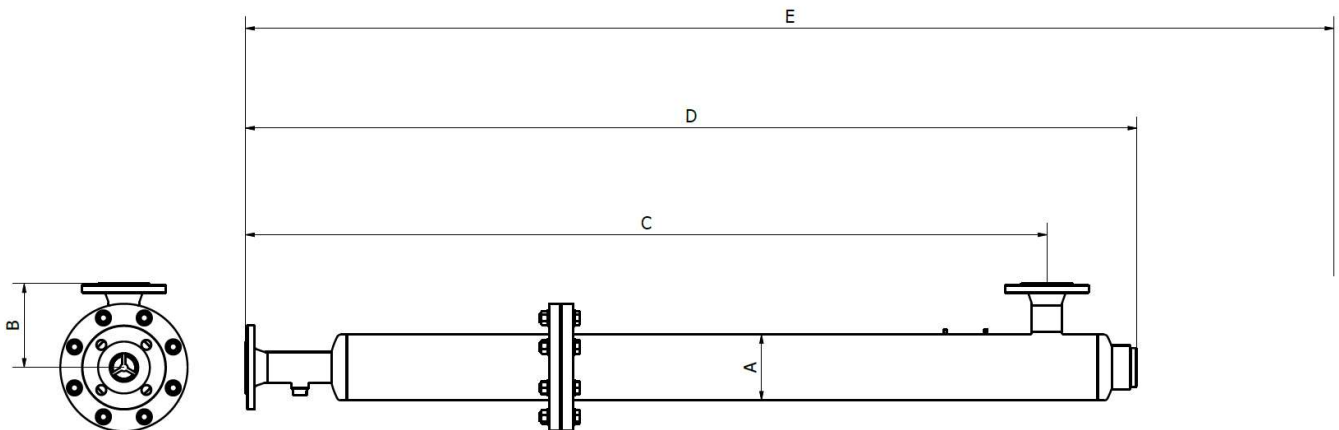

Type	A (mm)	B (mm)	C (mm)	D (mm)	E (mm)
150	88,9	144,5	1576	1750	3500
250	129	164,5	1576	1758	3516
500	204	202	1576	1772	3544

6.2 Control unit

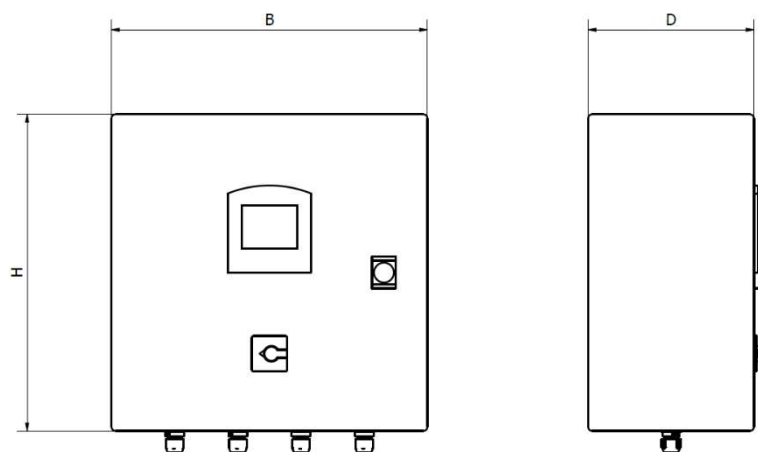

Type	H (mm)	B (mm)	D (mm)
150			
250	400	400	210
500			

7 Technical specifications

Supply voltage	: 230 V AC ± 10%
Frequency	: 50/60 Hz
Recommended ambient temp.	: 5 ° C - 35 ° C
IP level	: 54
Type lamp cable	: Colour coded WH-YE-GR-BR (4x1mm ²) water block.
Lamp type	: Low pressure UV-C lamp
Maximum system pressure	: 10 bar
Recommended water temp.	: 5°C - 30°C
Type reactor coupling	: Arnite plastic
Alarm	: Alarm contacts for pre and main alarm

Type	Lamp power	Max lamp lifespan ¹
150	350 WLL	12.000 hrs
250	600 WLL	12.000 hrs
500	600 WLL	12.000 hrs

¹ Frequent starting shortens the life of the UV-C lamp

8 Device requirements

To install the appliance successfully, requirements are imposed on the installer and the environment. The installation is covered in the parts [13. Control unit \(p. 12\)](#) and [14. Reactor chamber \(p. 15\)](#).

8.1 Requirements on the installer

The device, any software and components, must be installed by an authorized person. This authorized person must meet the following requirements:

- Be familiar with this device, which means that training has been given at the supplying agency, or practical knowledge has been gained with the device.
- Sufficient general knowledge of installation technology for electrical and water-side installation.

8.2 Requirements on the environment

The following aspects must be considered when installing the device:

- The IP value of the device is in accordance with the environment.
- The ambient temperature meets the specification issued by the manufacturer.
- The air humidity meets the specification issued by the manufacturer.
- The device must not be exposed to direct sunlight.
- The device must not be exposed to salts and/or acids.
- The space around the device must be provided with enough light to operate and maintain it.
- Allow sufficient space around the device for operation and maintenance. Take a full length of the reactor chamber as free space for replacing the UV-C lamp.



8.3 Requirements on the electrical installation

When installing the device electrically, the following aspects must be observed:





- Very frequent switching of the UV-C lamp ensures that the lifespan is reduced. As a rule of thumb, take a cooling time of 5 minutes after switching off the UV-C lamp.
- The UV-C lamp needs about 2 minutes to generate the maximum UV-C output.
- Provide a stable power source according to specification. Use an earth leakage circuit breaker according to specification.
- Apply a safety ground for both the control unit and reactor chamber.
- Use the alarm contacts if there is no direct view of the device.

9 Safety measures & regulations

Read and follow the basic instructions and warnings indicated in this manual. There are three types of warnings, classified according to the severity of the danger. The symbols and signal words used are explained in the following table:

Symbol / signal word	Description
 DANGER	Marks aspects that could result in serious injury or death if ignored or misused.
 WARNING	Marks aspects that could result in serious injuries if ignored or misused.
 CAUTION	Marks aspects that result in injuries or damage if ignored or misused.

In addition, there are a number of symbols that complement the symbol and signal word. See the explanation of these symbols below:

SYMBOL	Explanation
	Wearing safety goggles is mandatory. The safety glasses must comply with the marking 2C-1.2 (EN 170:2002)
	Wearing a safety face shield is mandatory. The safety face shield must comply with the marking 2C-1.2 (EN 170:2002)
	Wearing of protective clothing is mandatory.
	Wearing gloves.
	Electricity / electric voltage.



Warm / hot surface.



Electrostatically sensitive component.



UV-C radiation.

10 Environment & Scrapping

The UV-AOP system consists of various parts, please observe the local and international legislation for the disposal of this device.

The following components must be disposed of separately:

- Quartz sleeve
- UV-C Lamp
- Control unit



When decommissioning the UV-AOP device, the following procedure must be followed:

- Check that the electricity is switched off and that the liquid supply is switched off / blocked;
- Disconnect the electricity and remove the cables;
- Drain the device and the pipes and collect the contents. Dispose of the collected liquid in a responsible manner if necessary;
- Disconnect the pipes;
- Disassemble the installation.

11 Logbook

It is advisable to record malfunctions and maintenance-related activities. This can vary from replacing a UV-C lamp to repairing a leak.

It is important that faults, incidents and/or maintenance are centrally recorded. The appliance is subject to the warranty conditions, as described in the 2019 Metaalunie conditions, Article 14: Guarantee and other claims.

After installation

Record the commissioning date, location information, serial number and device type.

Standard recording

Record after each activity which actions were performed and on what date this took place. In addition, it is important to note the system and lamp hours as well as the number of system and lamp starts. Finally, note which parts have been replaced by date.

12 Optional Temperature protection

By applying a temperature protection it is possible to protect the UV-C lamp against overheating. The temperature is measured indirectly by a thermocouple mounted on the outside of the reactor chamber. If the measured temperature is above the pre-alarm value, only a notification will be generated. As soon as the main alarm value is exceeded, the UV-C lamp will be switched off preventively.

Default setting : Pre-alarm ≥ 35 degrees
 : Main alarm ≥ 45 degrees

The above settings are adjustable. See section [18.5 Settings \(p. 34\)](#).

13 Control unit

The control unit is an essential part of the device and houses the electronics that control the UV device. See below the explanation of the different parts:

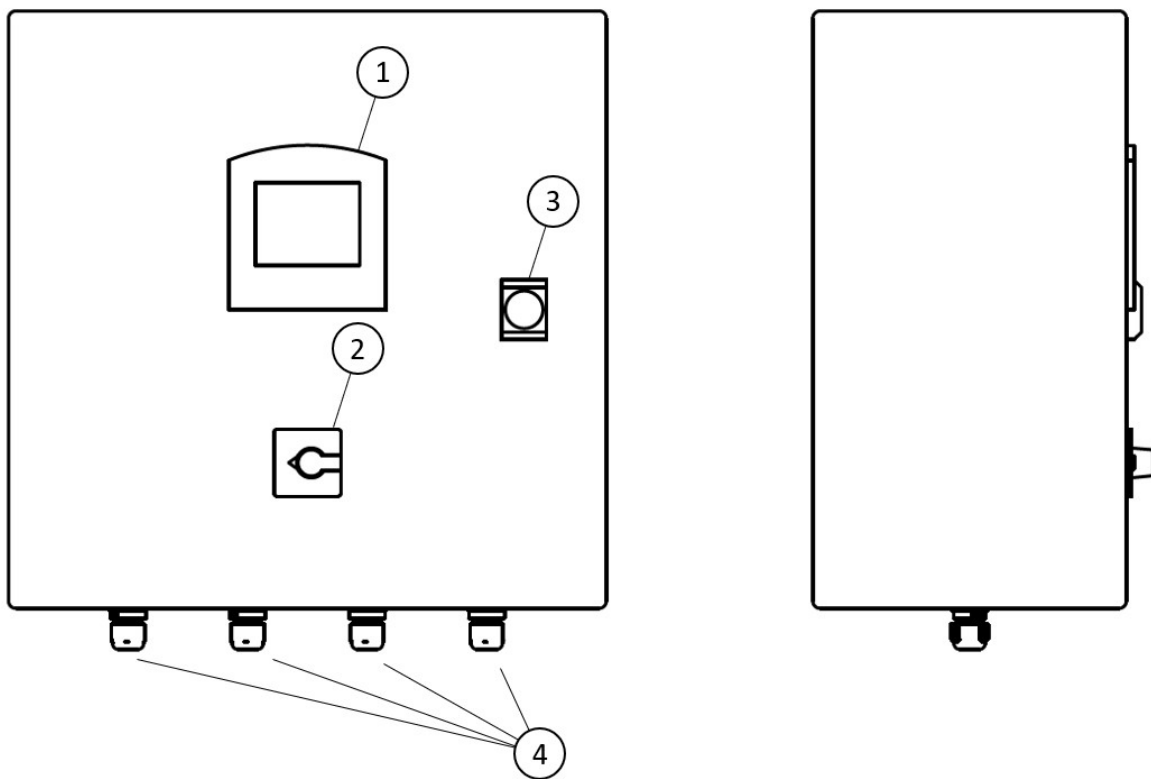

The image above is an illustration

Item	View	Part	Description
1	Front	HMI screen	Touchscreen for operating the system
2		Main switch	For switching on/off the 230VAC
3		Lock	Locking the control cabinet
4		Cable glands	Cable outlets for main power, lamp cable, alarm outputs and sensor inputs

13.1 Dimensions

The size of the control unit depends on the type of device.
For this, see section [6. Dimensions \(p. 8\)](#).

13.2 Mounting

The control unit must be mounted within the range of the supplied cable length.
The unit must be installed by a qualified installer.

13.3 Alarm contacts

Potential-free changeover contacts are applied to the terminal strip.

Pre-alarm : Warning, no consequences for the operation.

Main alarm : Failure status, UV-C dose is not guaranteed.

See sections [18.5 Settings \(p. 24\)](#) for the alarm settings of the temperature sensor. These settings affect, among other things, the activation of these alarms.

13.4 Installation



WARNING



- Observe the device requirements for installation.
 - Electrically use an earth leakage circuit breaker to secure the device and ensure safety. See section [7. Technical specifications \(p. 9\)](#).
1. Attach the control unit to a suitable surface and take into account the maximum cable length of the UV-C lamps related to the distance to the reactor chamber.
 2. Connect the control unit electrically, see [13.5 Electrical connection \(pg.14\)](#).
 3. Provide a safety grounding.
 4. Visually check that all cables and components are installed correctly and that there are no damages. This is due to the safety and operation of the device.

13.5 Electrical connection

See the meaning per terminal below. The terminals available depend on the type of device. Certain terminals may not be used as shown below.

13.5.1 Terminal strip

X0 Main current

Description 1	Description 2	Terminal number
Power IN L	230VAC Phase	L
Power IN N	230VAC Neutral	N
Earth	Protective Earth	PE

X3 Remote start

Description 1	Description 2	Terminal number
Remote start	24VDC	1
Remote start	Remote start	2

X5 Alarm outputs

Description 1	Description 2	Terminal number
Main alarm	Common (COM)	4
Main alarm	Normally closed (NC)	5
Main alarm	Normally open (NO)	6

13.6 Use

When the device is installed according to safety standards and instructions, the device can be put into operation. See section [15. Commissioning \(p. 17\)](#).

The device is equipped with multiple control PCAs. With this component the device can be operated and adjusted.

13.7 Maintenance

The UV-C lamp cable is the only part used within the control unit that has a replacement period. In addition, there are electrical components used that can malfunction.

If it is not clear how to replace these components, consult your supplier for more information.

13.8 Failure

The device uses software and electronics that respond to various situations. For this reason, it is recommended that you check before repair or replacement what caused the malfunction. Before contacting your supplier, make sure that the device parameters are known.

For more insight in failure events, see section [18.6. Alarm \(p. 24\)](#).

14 Reactor chamber

The reactor chamber is an essential part of the UV-AOP device. The reactor chamber is designed to remove micropollutants. The axial design in combination with the unique flow mixer ensures a high UV-C dose resulting in effective removal.

The dimensions, diameter and design of the reactor chamber depend on the type of device. See an illustration of the reactor chamber below.

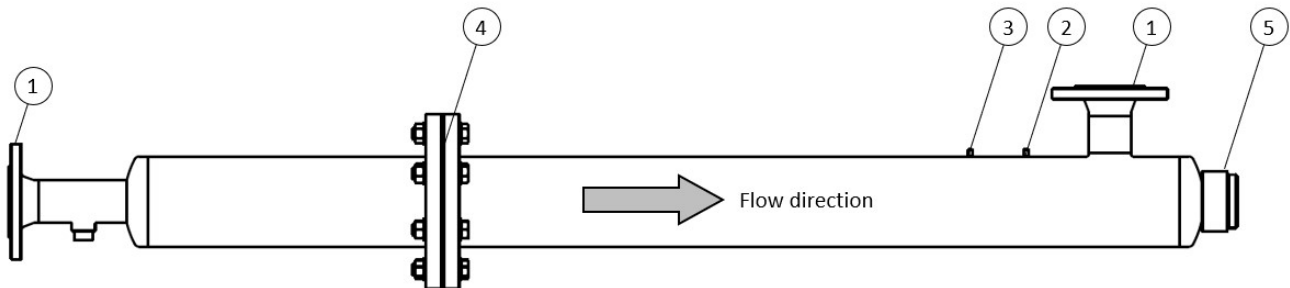

Item	Part	Description
1	Connection	For the installation of the reactor water side. See section 6, Dimensions (p. 8) .
2	M6 pin	For the application of a safety grounding
3	M6 pin	For fixing a thermocouple to protect the UV-C light against too high a temperature.
4	Flange connection	Allows disassembly of the flow mixer part of the reactor
5	Reactor coupling	The reactor coupling forms a set with the locking sleeve and O-ring to seal the quartz sleeve

14.1 Installation

Within this chapter the installation of the reactor chamber is described step by step.



WARNING

- Observe the device requirements for installation.
- Install the device **horizontally**
- It is recommended to use a bypass which can isolate the reactor chamber within the piping circuit, for maintenance purposes.
- Provide a drain and aeration point within the piping circuit if the reactor chamber does not have this option.
- Prevent vibrations in the circuit, to prevent damage and water hammer.

It is recommended to install the reactor chamber without UV-C lamp(s). For (dis)mounting the UV-C lamp, see section [16. UV-C lamp \(p. 18\)](#). The following steps relate to the illustration on the previous page.

1. Mount the reactor on a suitable base.
2. Connect the reactor on the water side **(1)** and take into account the water flow direction, which flows from left to right.
3. Install an electrical safety ground **(2)**.
4. Fix the thermocouple to the other M6 pin **(3)**. (optional)
5. Check by hand that the reactor couplings **(5)** are sufficiently tightened (hand tight).

14.1.1 Pressure test

After the installation has been completed in its entirety, the circuit can be supplied with liquid up to and taking into account the maximum working pressure. During this step, check that the various connections and couplings are free from leaks. If this is the case, the installation of the UV-C lamp can be started. If there is a leak, first dry it completely, fix the leak and carry out a pressure test again.



If the maximum working pressure is increased after installation, perform a pressure test as above, with the UV-C lamps removed

14.2 Use

When the appliance is installed in accordance with the locally applicable safety standards and instructions, the appliance can be switched on. See section [15. Commissioning \(p. 17\)](#).

14.3 Maintenance

UV-C light accelerates the aging of various components installed in the reactor chamber. The material properties deteriorate qualitatively due to the UV-C radiation. To guarantee safety and function, it is necessary to replace these components in time. Refer to section [19. Replacement Parts \(p. 25\)](#) for information on applicable components and replacement intervals.

14.3.1 Cleaning

In addition to the preventive replacement of components, cleaning the quartz tube is a maintenance issue. If organic material is present in the liquid to be treated and if the hardness of the water is high, it may occur that deposition takes place on the quartz tube. This impedes the transmission of UV-C radiation, which reduces the disinfecting effect of the system. Make sure that the correct safety measures are observed and that the correct personal protection is used during cleaning, see the instructions per cleaning agent.

14.3.1.1 Cleaning agents

See here below some suggestions when it comes to cleaning the different components.

Agent	Description
Lactic acid <20% solution	Removes lime, calcium, rust, magnesium and other dissolved minerals
Sulfamic acid <10% solution	Removes lime, calcium, rust, magnesium and other dissolved minerals
Phosphoric acid <30% solution	Removes lime, calcium, rust and colour stains
Citric acid <20% solution	Removes mineral scale deposits
Sodium hypochlorite <6% solution	Removes oil and grease
Acetic acid <20% solution	Removes oil and grease
Sulphuric acid <10% solution	Removes oil and grease
Innosoft B570	Removes superficial rust reactor chamber

15 Commissioning

Before commissioning, see the parts listed below for more information about the installation and other instructions:

[13.4 Control unit – Installation \(p. 13\)](#)

[14.1 Reactor chamber – Installation \(p. 15\)](#)



When the appliance is installed in accordance with the locally applicable safety standards and instructions, the appliance can be switched on for the first time.

15.1 Start-up device

- Switch on the power supply.
- Switch on the control unit by turning the Main switch.
- The HMI screen will activate and show the main menu. The system will then start up by running the ignition process for the UV-C lamps. During this time, the mode is displayed as STOP. Once the lamps have been successfully ignited, the mode will change to RUN meaning there are no faults and the UV-C lamps are active.
- **Perform the following checks after the device has been put into operation:**
 - Check that the flow rate is correct and does not exceed the maximum treatment flow rate of the UV-AOP device. If the flow rate is higher than the prescribed maximum, the dose will be too low. In that case, the UV-C dose is not guaranteed.
 - Check that the parameters of the device are correct, related to the lamp power, and activated modules if installed.

15.2 Operation

The device contains a HMI screen which can be used for operating the device. Using the touchscreen and the information that it displays, settings can be adjusted and it is possible to retrieve device information such as the operating status. See section [18. Touch screen interface \(p. 23\)](#).

16 UV-C lamp

The UV-C lamp must be replaced after the maximum lifetime has expired. Normally this is done on the basis of the maximum number of burning hours. This service life in burning hours differs per lamp and is shortened by the above-average frequency switching on and off of the UV-C lamp. Refer to [7. Technical specifications \(p. 9\)](#) for this information.



WARNING

It is important to follow the replacement period of this part to guarantee the functioning of the device.



- (1)** Plug connection of the UV-C lamp.
- (A)** Filaments that are connected to the connection pins **(1)** of the UV-C lamp.
- (B)** Wires to connect the rear filament with the connection pins **(1)** on the front.

16.1 Lamp connector

The UV-C lamp has two filaments on the inside of the UV-C lamp.

These filaments are connected to the connection pins **(1)**.

The top view **(2)** shows that there is a difference. The PINS with a distance of 7mm are connected to one filament.

The lamp plug connection **(3)** also has these distances. This makes it possible to mount the lamp plug in two ways. Both ways are correct.

The mounting of the lamp plug must be done carefully to ensure the functioning of the device.

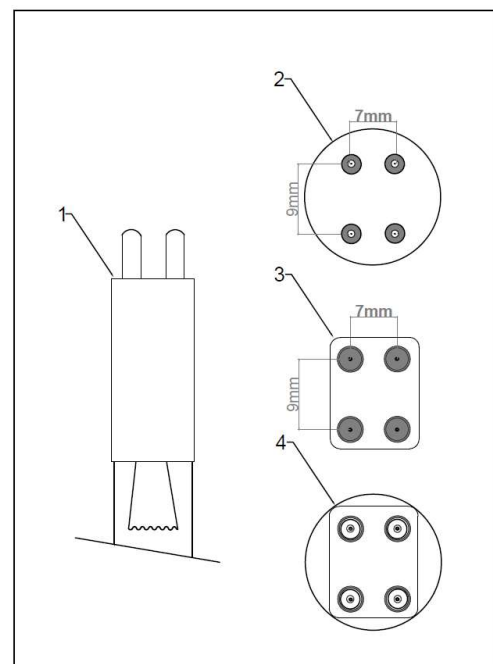

16.2 Disassembly



WARNING



- Switch off the UV-C device and electrically isolate the device.
- Release the reactor chamber from water pressure and insulate it within the piping circuit if possible.
- Let the appliance cool down for at least 10 minutes.
- Use the supplied fabric gloves to prevent fingerprints on the quartz glass. See the illustration below for more insight into the assembly parts.
- **(A)** concerns the UV-C lamp, **(B)** the quartz tube and **(C)** the safety spring.

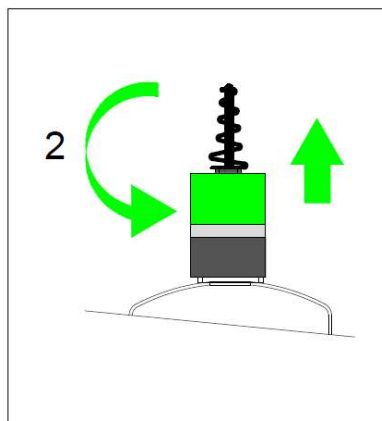
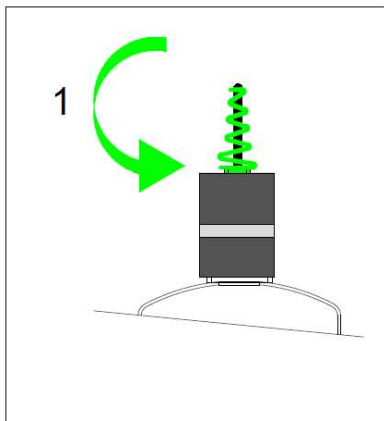

1. Loosen the spiral cap or swivel, so that the lamp cable is exposed.
2. Hold the reactor coupling and unscrew the lamp cable cap.

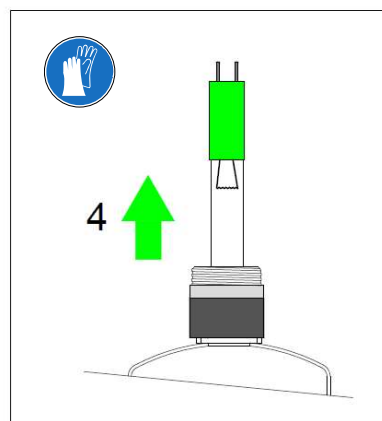
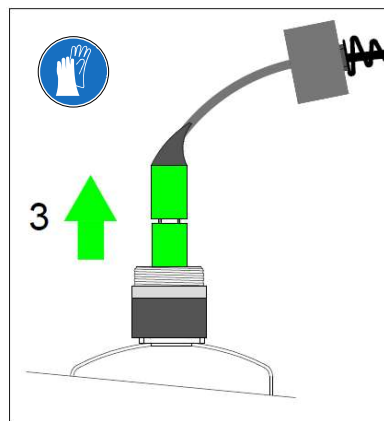

3. Slide the lamp cable cap back and pull the lamp cable out of the reactor chamber. Using the supplied gloves, grasp the UV-C lamp and disconnect the lamp cable.
4. Remove the UV-C lamp from the quartz sleeve and put it in a safe place.



16.3 Assembly

The mounting of the UV-C lamp must be carried out in reverse order compared to the dismantling. Use the supplied fabric gloves to prevent fingerprints on the glass.

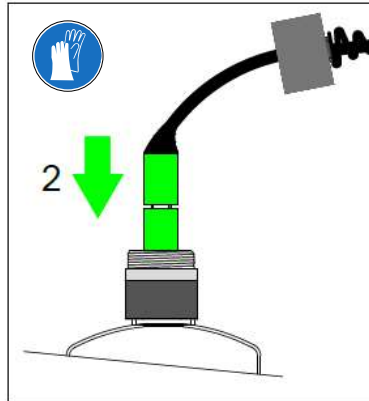
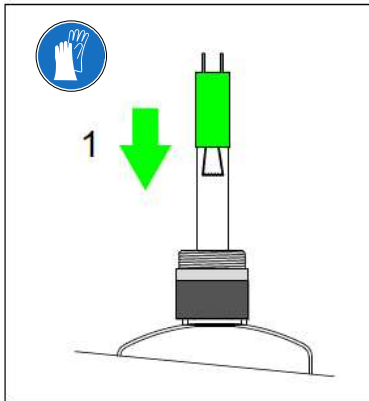

1. Check if there is a safety spring in the quartz tube. Then slide the UV-C lamp 80% into the quartz tube.
2. Connect the lamp plug to the UV-C lamp and position the UV-C lamp so that the jumper wires **(E)** are aimed towards the bottom of the reactor.

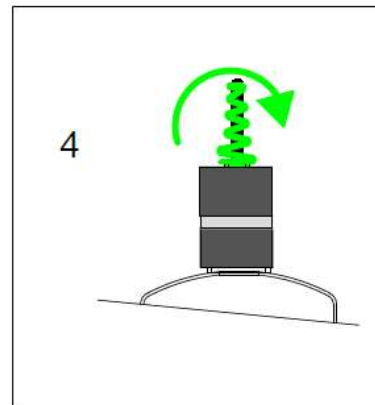
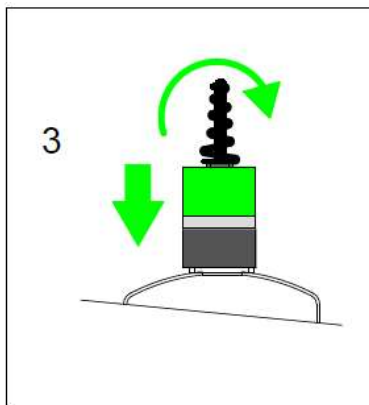

3. Tighten the lamp cable cap clockwise to a maximum of 10Nm. (The lamp cable cap does not serve as a seal for the quartz sleeve).

(D) Press the UV-C lamp into the quartz tube by sliding the lamp cable inwards until a resistance can be felt, caused by the counterpressure of the safety spring.

4. Tighten the spiral tip clockwise to position the UV-C lamp correctly. To prevent the UV-C lamp from rotating, it is recommended to hold the lamp cable while tightening the spiral top.

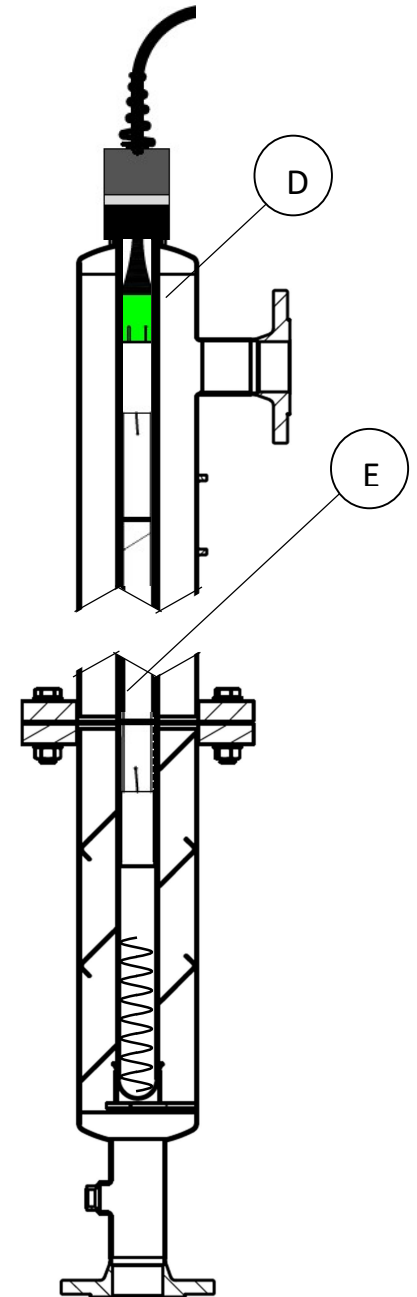

Make the device operational for resumption UV-AOP process if applicable.



WARNING

16.4 Resetting UV-C lamp hours

If a UV-C lamp has been replaced, the remaining lamp hours must be reset in the software menu of the touch screen interface. This is done in the 'lamps' menu. This menu gives an overview of the all lamps in the system, their remaining burning hours and the number of times the lamp has been started.

Select the lamp that has been replaced in the menu and press 'reset'. The HMI will ask for confirmation and shows to what value the lamp hours will be reset. Click YES to definitively reset the hours for this lamp.

17 Quartz sleeve

The quartz sleeve is the housing of the UV-C lamp and is mounted in the reactor chamber. The material of the tube is quartz glass, which allows the UV-C radiation generated by the UV-C lamp to pass through to the liquid.

Due to UV-C radiation, this part is subject to wear. To guarantee the functioning of the device, it is important to follow the replacement period for this part and to clean the part in time. For the cleaning section see [14.3.1 Reactor chamber – Cleaning \(p. 16\)](#).

17.1 Disassembly



WARNING



- Switch off the UV-C device and electrically isolate the device.
- Release the reactor chamber from water pressure and insulate it within the piping circuit if possible.
- Drain the liquid present in the reactor chamber.
- Let the appliance cool down for at least 10 minutes.
- Use the supplied fabric gloves to prevent fingerprints on the glass.
- Disassemble the UV-C lamp. See section [16.2 UV-C lamp – Disassembly \(p. 19\)](#).

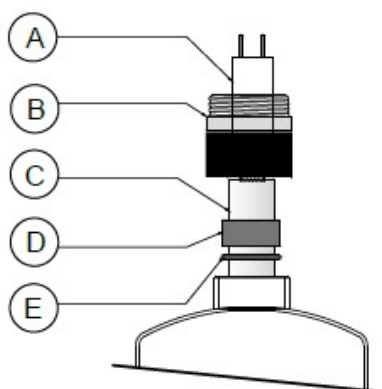

Overview of various components:

- A** UV-C lamp
- B** Reactor coupling
- C** Quartz sleeve
- D** Locking sleeve
- E** O-ring

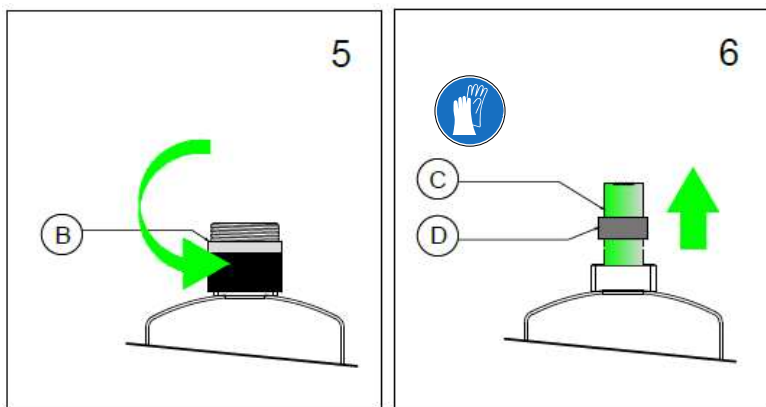

5. Loosen the reactor coupling **(B)** counter clockwise and put it in a clear place.
6. Carefully pull the quartz tube **(C)** out of the reactor chamber and remove the locking sleeve **(D)**.

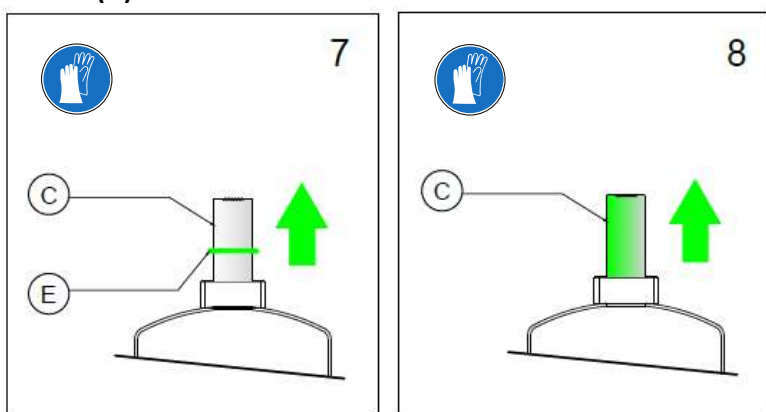

7. Pull out the quartz sleeve **(C)** so that the O-ring **(E)** is visible. Slide the O-ring off the quartz sleeve.
8. Remove the quartz sleeve **(C)** from the reactor chamber.

17.2 Assembly

The mounting of the quartz sleeve must be carried out in the reverse order of the disassembly. Use the supplied fabric gloves to prevent fingerprints on the glass. Always replace the O-ring **(E)** after dismantling the quartz sleeve.

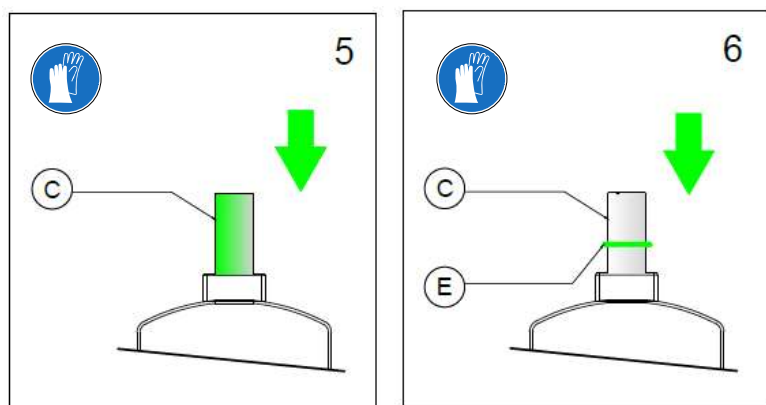

5. Place the quartz sleeve **(C)** in the reactor chamber.
6. Take a new O-ring **(E)** and slide it over the quartz sleeve.

See to the right a locking sleeve and an O-ring. As can be seen, the locking sleeve has a chamfered and a flat side.

Flat side Easy positioning of the O-ring
Chamfered side Sealing quartz sleeve.

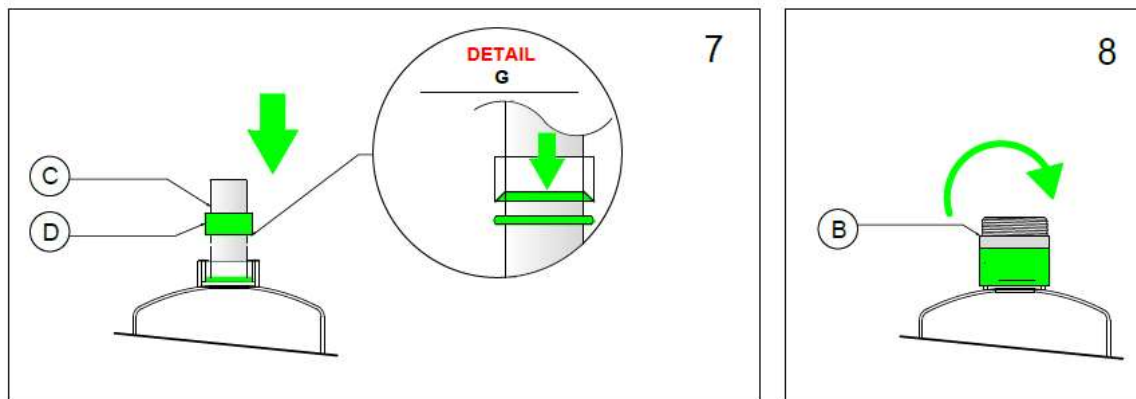
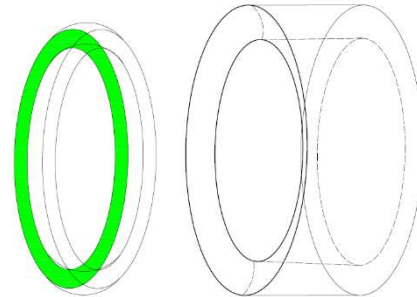

7. With the flat side of the locking sleeve (**D**), press the O-ring into position, pull the quartz sleeve (**C**) back sufficiently (50 mm) to ensure that it fits against the reactor coupling. Turn the locking sleeve (**D**) over so that the chamfered side is pressed against the O-ring (**detail G**).
8. Mount the reactor coupling (**B**) by tightening it clockwise to a maximum of 25Nm. After tightening, feel whether the quartz sleeve is fixed against the edge of the reactor coupling.



WARNING

Perform a pressure test after the assembly work to prevent damage to other parts.

Make the device operational for resumption UV-AOP process if applicable

18 Touch screen interface

The control unit has a touch screen that can be used to operate the UV system. The start screen is the main menu. From the main menu it is possible to navigate to a couple of screens that will be explained below. Within the menu there are a couple of levels of authorization linked to a login function. Some functions of the menu can only be accessed or executed with a high enough level of authorization.

18.1 Info

General information about the UV system is displayed under 'Info'.

18.2 Login

In the login screen, there are three levels that can be logged in to. To login click the **** button, fill in the password corresponding with the concerned login level and click login to confirm. After the required changes to the system have been performed, go back to the login screen and click logoff to clear the access that comes with each login level.

In short: Click **** -> fill in password -> Enter -> click 'login'

Passwords:

Level 1 – 8131 (User)

Level 2 – 1891 (Installer)

Level 3 - **** (Van Remmen UV Technology)

Functions:

Level 1 – Change language, reset lamp hours

Level 2 – Change alarm settings

18.3 Language

This menu offers the possibility to change the language of the interface.

18.4 Lamps

The lamp menu shows all lamps that are part of the system. For each lamp the number of remaining burning hours is displayed, as well as the number of times the lamp has been ignited.

The lamp hours count down from 12.000 hours. When this amount reaches zero the lamp needs to be replaced as it cannot longer produce the required UV-C dose.

After a lamp has been replaced, select it in the menu and press 'reset' in the screen. The HMI will ask for confirmation and shows to what value the lamp hours will be reset. Click YES to definitively reset the hours for this lamp.

18.5 Settings

In this menu the settings for temperature sensor can be viewed and adjusted. Values can be entered for when the pre-alarm and main-alarm are triggered. Changing these settings can only be done with a level 2 login. Change the settings by pressing on the value that needs to be adjusted.

Recommended values:

Temperature:

Main alarm: 45 degree

Pre alarm: 35 degree

18.6 Alarm

The alarm menu shows a list of events that have to do with triggering a pre alarm of main alarm. By pressing the magnifying glass more information is shown on the time and details of these events.

19 Replacement parts

A number of parts of the UV-AOP unit have a replacement interval:

Item	Interval
UV-C lamp	Maximum number of burning hours, 350W and 600W lamps need to be replaced after 12.000 hours of use.
Sealing O-ring	If the quartz sleeve is disassembled, the O-ring must be replaced to prevent leaks.
Lamp cable	The UV-C lamp cable must be replaced at least 1x every 4 years . The cable must also be replaced after leakage. If this is not done, the operation of the UV-C lamp will not be guaranteed.
Quartz sleeve	The quartz sleeve must be replaced at least 1x every 4 years , depending on the condition.
Reactor coupling	The plastic coupling (black) must be replaced at least 1x every 4 years . Metal couplings have no replacement interval.

19.1 Parts list

UV-C lamp	Code	150	250	500
350W LL	123502.001	1		
600W LL	124013		1	1
Sealing O-ring	Code	150	250	500
O-ring Ø44mm quartz sleeve	250048.100		1	
Flange gasket	Code	150	250	500
DN80 Gasket Viton	250072	1		
DN125 Gasket Viton	250073		1	
DN200 Gasket Viton	250074			1
Lamp parts	Code	150	250	500
Safety spring Ø44mm	250110		1	
Lamp cable 3.0mtr	360240.300		1	
Quartz sleeve	Code	150	250	500
Ø44mm 1530mm	411652		1	
Reactor coupling	Code	150	250	500
Reactor coupling Ø44mm	263038		1	
Locking sleeve Ø44mm	263025.001		1	
Covercap 44mm M20 spiral top	263039		1	
Complete set Ø44mm incl. O-ring.	263044		1	
Lamp Driver	Code	150	250	500
Lamp Driver 350W	310215	1		
Lamp Driver 600W	310218		1	1