

QUICK INSTALLATION

SET 1501 T - 2501 T - 3501 T

SET 1501 H - 2501 H - 3501 H

en

It is the responsibility of the operator to read and understand this service manual and other information provided and to use the correct operating procedure.

Read the entire manual before the initial start-up of the unit. It is important to know the correct operating procedures for the unit and all safety precautions to prevent the possibility of property damage and/or personal injury.

It is the responsibility of the installer to ensure the conformity of all, not supplied cables towards national regulations.

de

Der Benutzer muss dieses Servicehandbuch und weitere bereitgestellte Informationen gelesen und verstanden haben und ist für den ordnungsgemäßen Betrieb verantwortlich.

Vor der ersten Inbetriebnahme des Geräts das ganze Handbuch durchlesen. Die Verfahrenswesen für einen ordnungsgemäßen Betrieb des Geräts und alle Sicherheitsvorkehrungen müssen bekannt sein, um Sachschäden und/oder Verletzungen zu vermeiden.













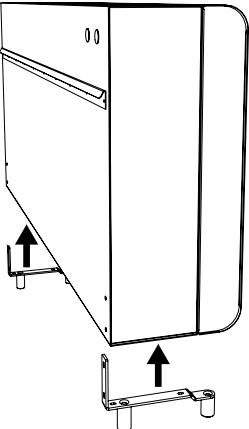

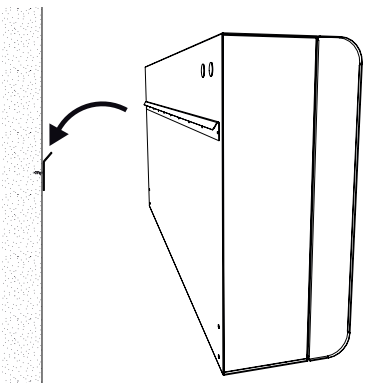
Der Installateur ist dafür verantwortlich, dass alle verwendeten Kabel, die nicht Teil des Lieferumfangs sind, den nationalen Vorschriften entsprechen.

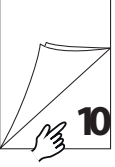
fr

Il relève de la responsabilité de l'opérateur de lire et de comprendre le présent manuel d'entretien, ainsi que les autres informations fournies et d'utiliser la procédure opérationnelle appropriée.

Il convient de lire entièrement le manuel avant le démarrage initial de l'unité. Il est important de connaître les procédures opérationnelles adaptées à l'unité, ainsi que toutes les précautions de sécurité afin de prévenir tous les dommages matériels et/ou corporels éventuels.

Il relève de la responsabilité de l'installateur d'assurer la conformité de tous les câbles non fournis avec les réglementations nationales.

| | | |
|---|---|--|
|  |  <p>SET (T)</p> | |
| |   <p>5</p> |   <p>7</p> |
| |  <p>SET (H)</p> |  <p>10</p> |
|  |  <p>SET (T)</p>  <p>SET (H)</p> |  <p>15</p> |
|  |  <p>SET (T)</p>  <p>SET (H)</p> |  <p>17</p> |



Download full version
<https://support.dantherm.com>

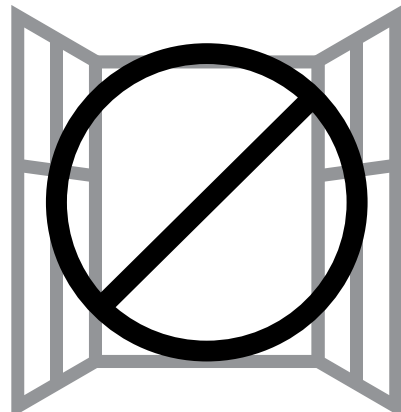
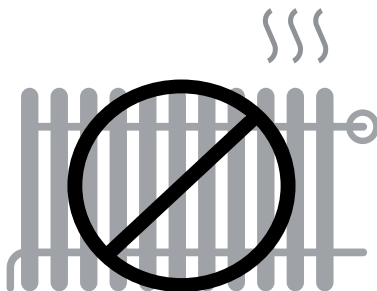
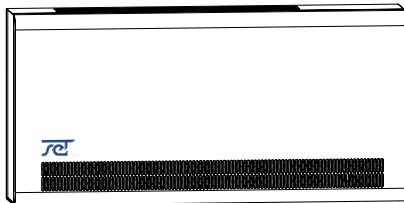
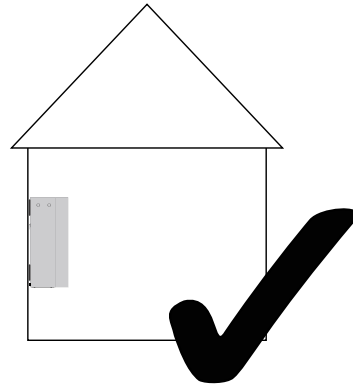
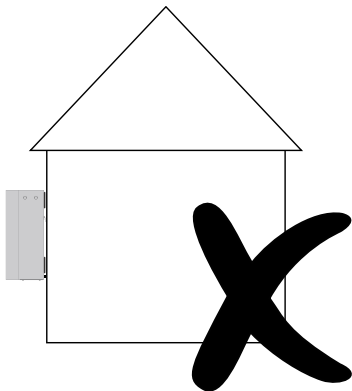

SET (T)

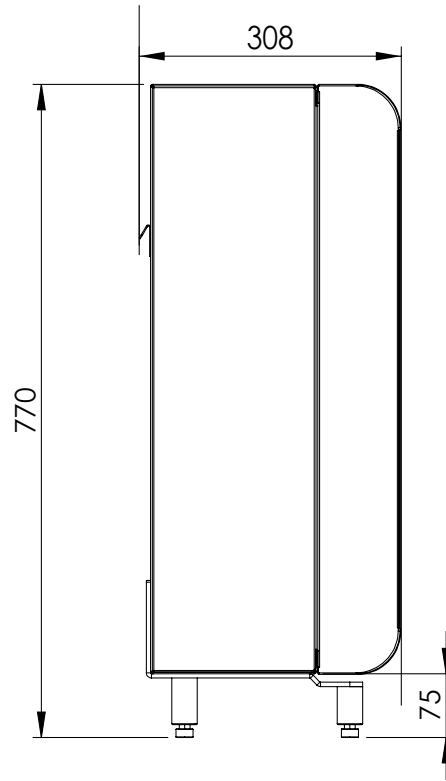
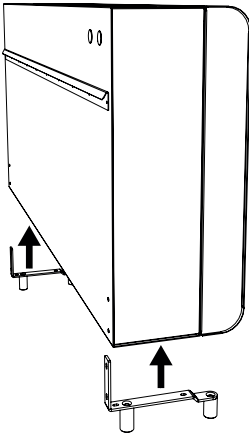
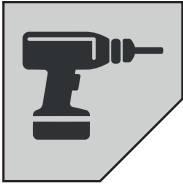

1

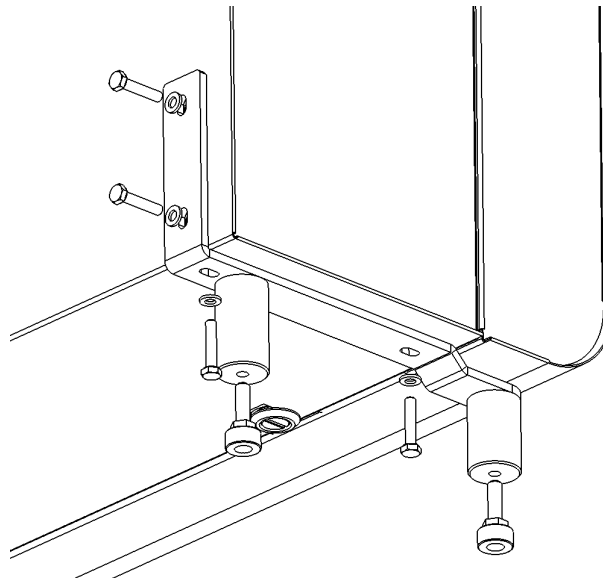

SET (T)



2

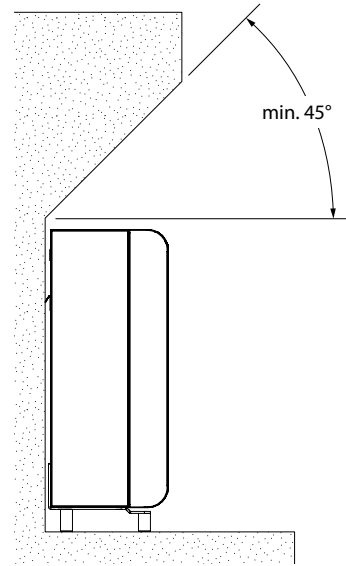
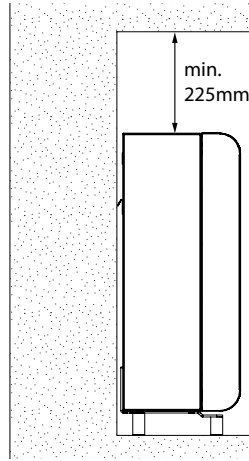

3

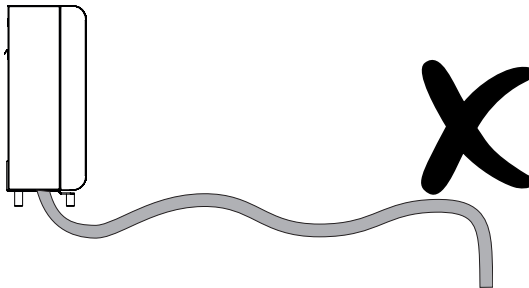
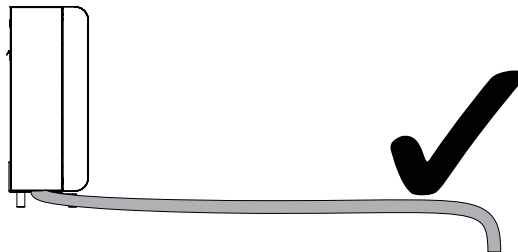

4



SET (T)

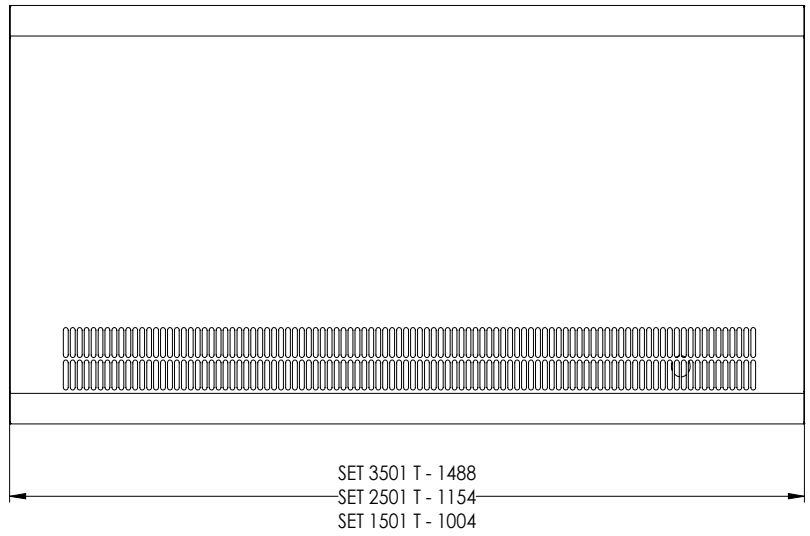
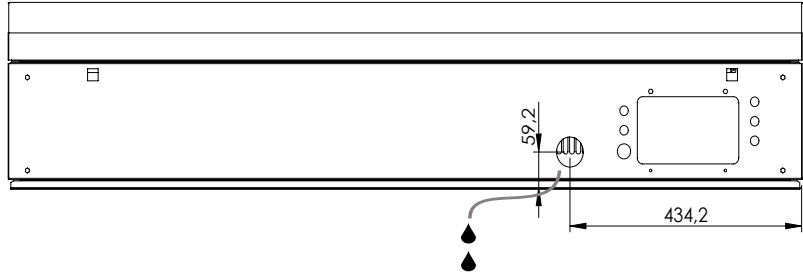
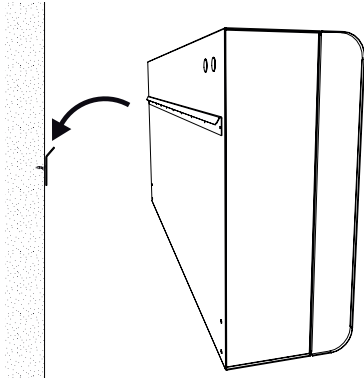

1

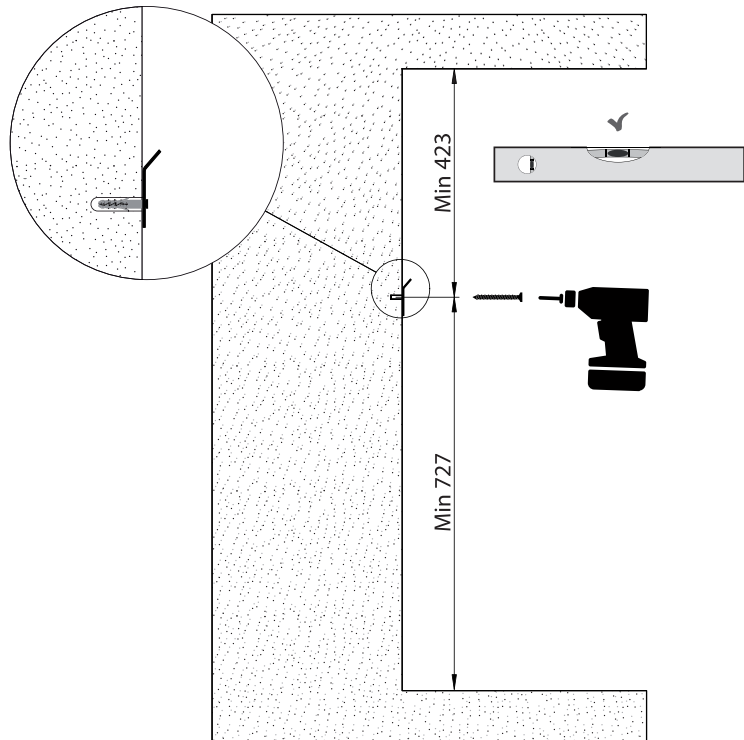
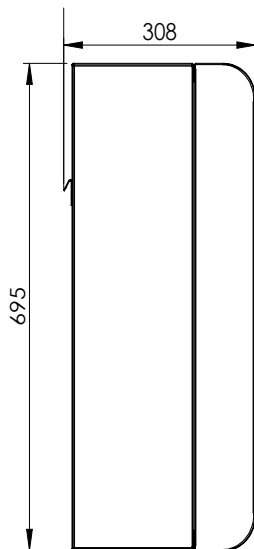

SET (T)



2

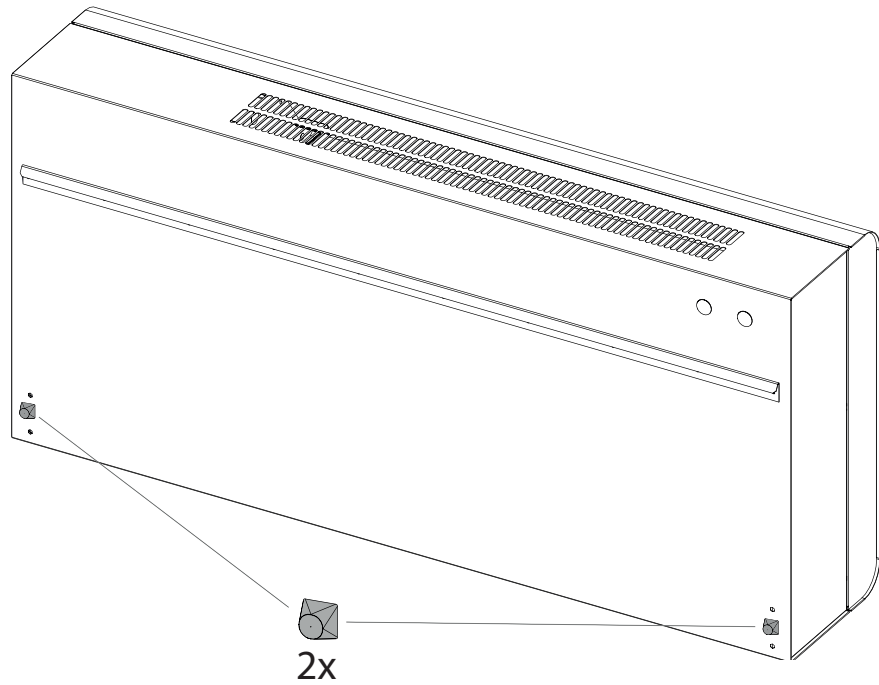

3

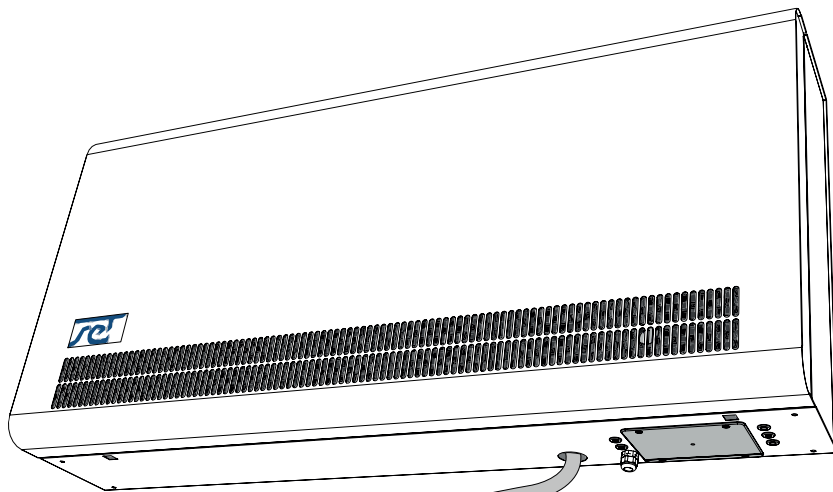

SET (T)

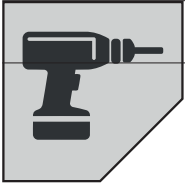

4

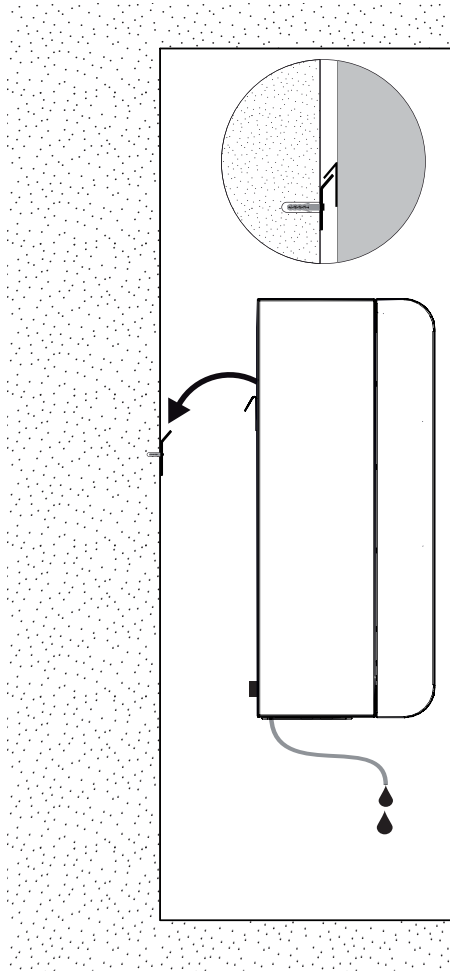

5

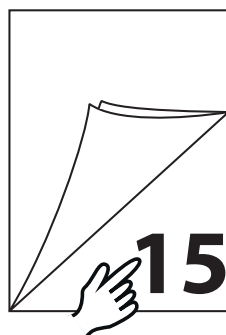

SET (H)

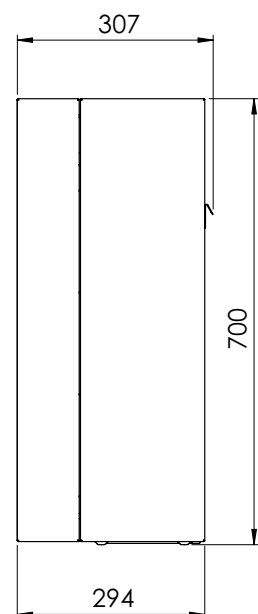
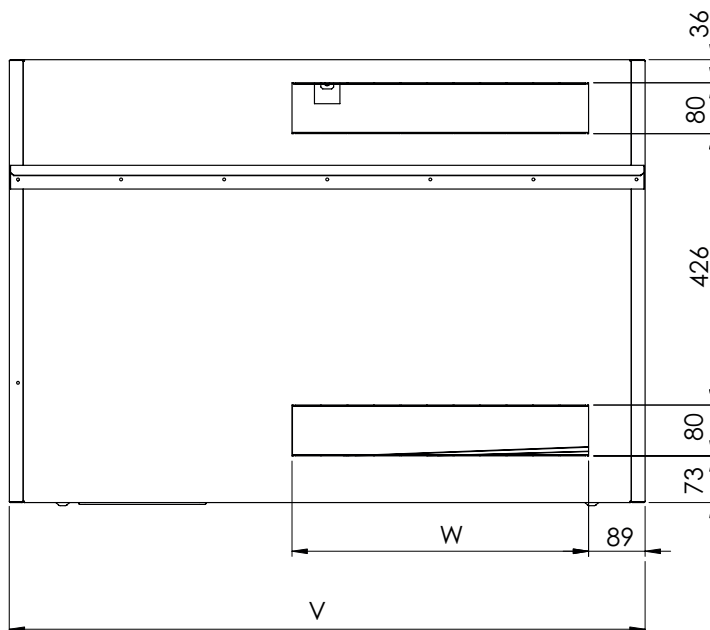
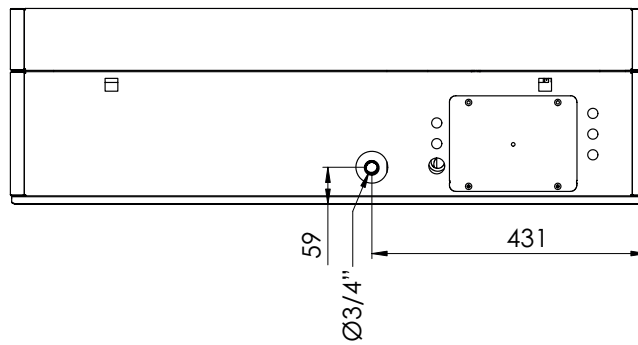
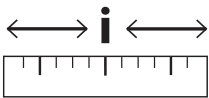
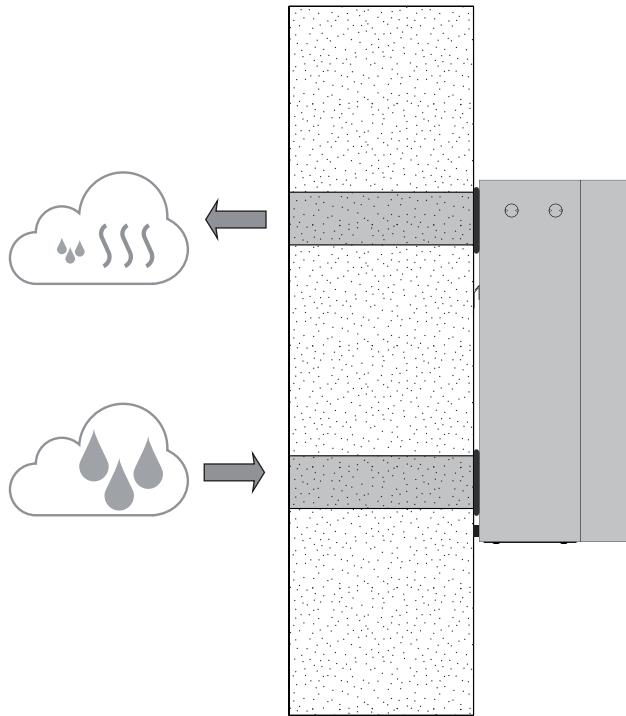

SET (H)

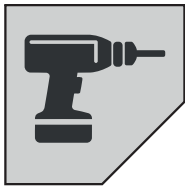

1

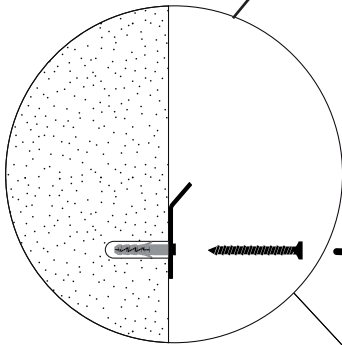
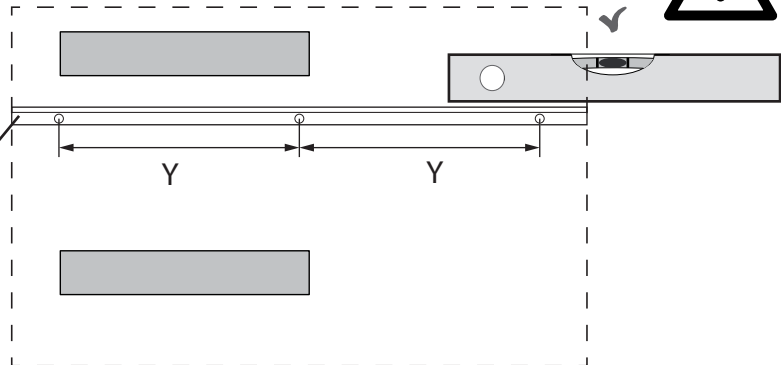

| | SET 1501 H | SET 2501 H | SET 3501 H |
|---|------------|------------|------------|
| Y | 437 | 341 | 450 |

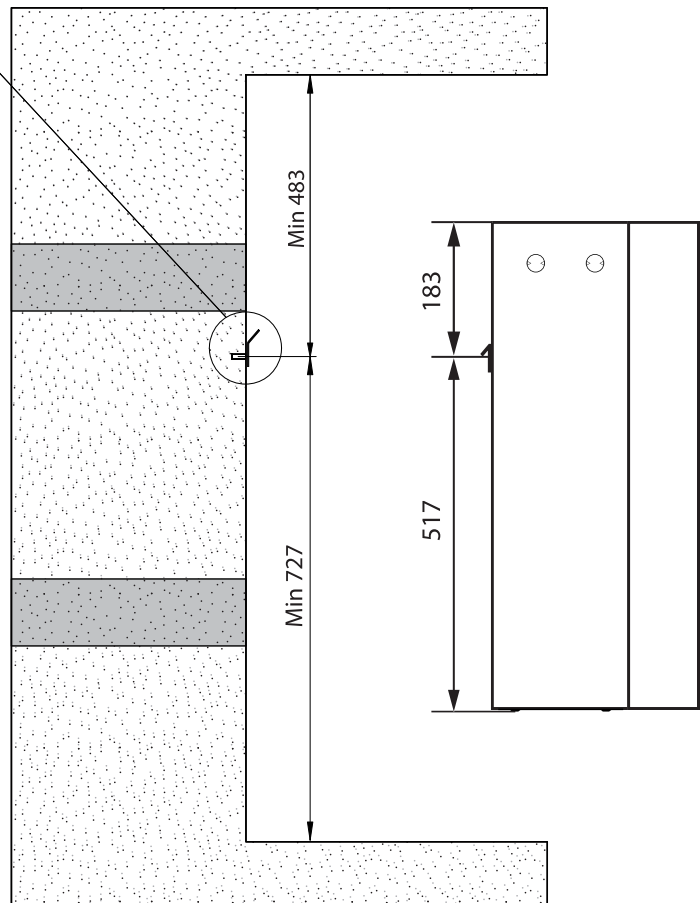
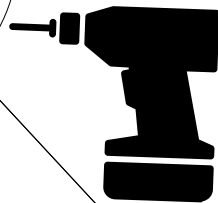

SET (H)

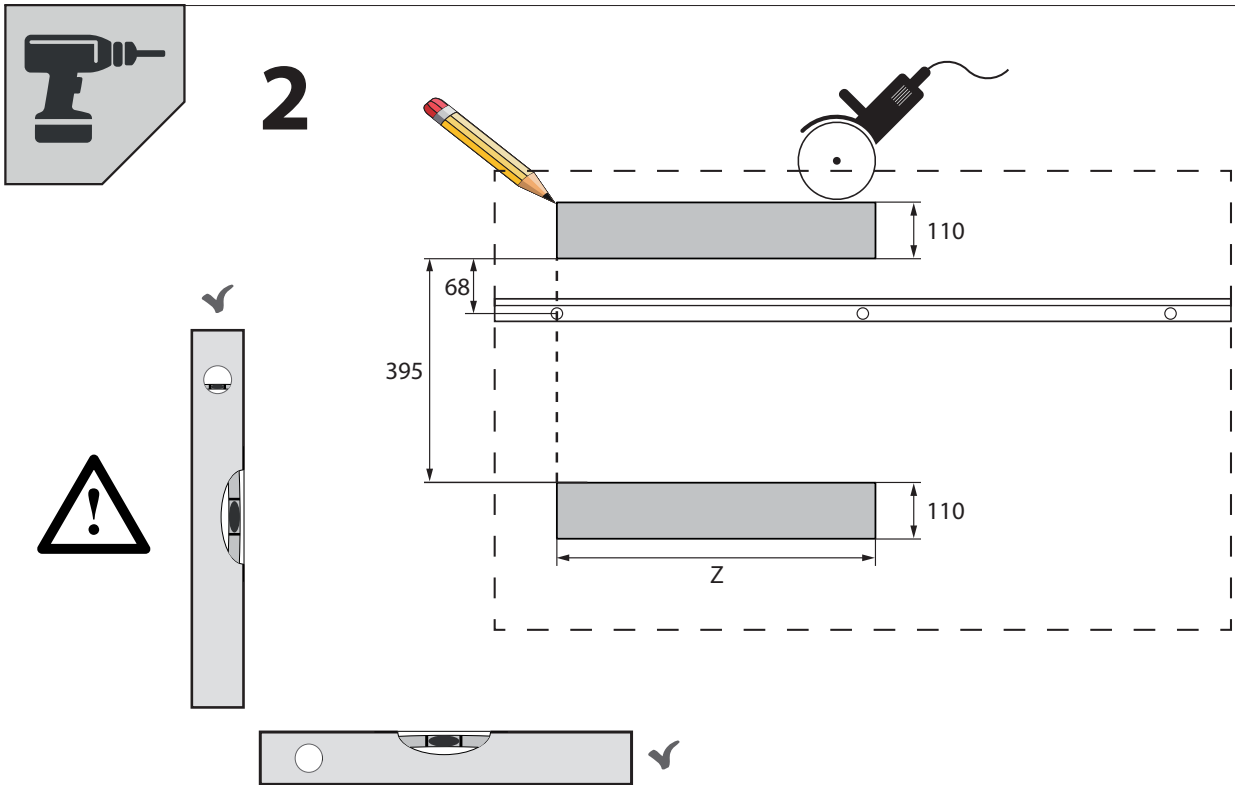

| | SET 1501 H | SET 2501 H | SET 3501 H |
|---|------------|------------|------------|
| Z | 610 | 760 | 1095 |

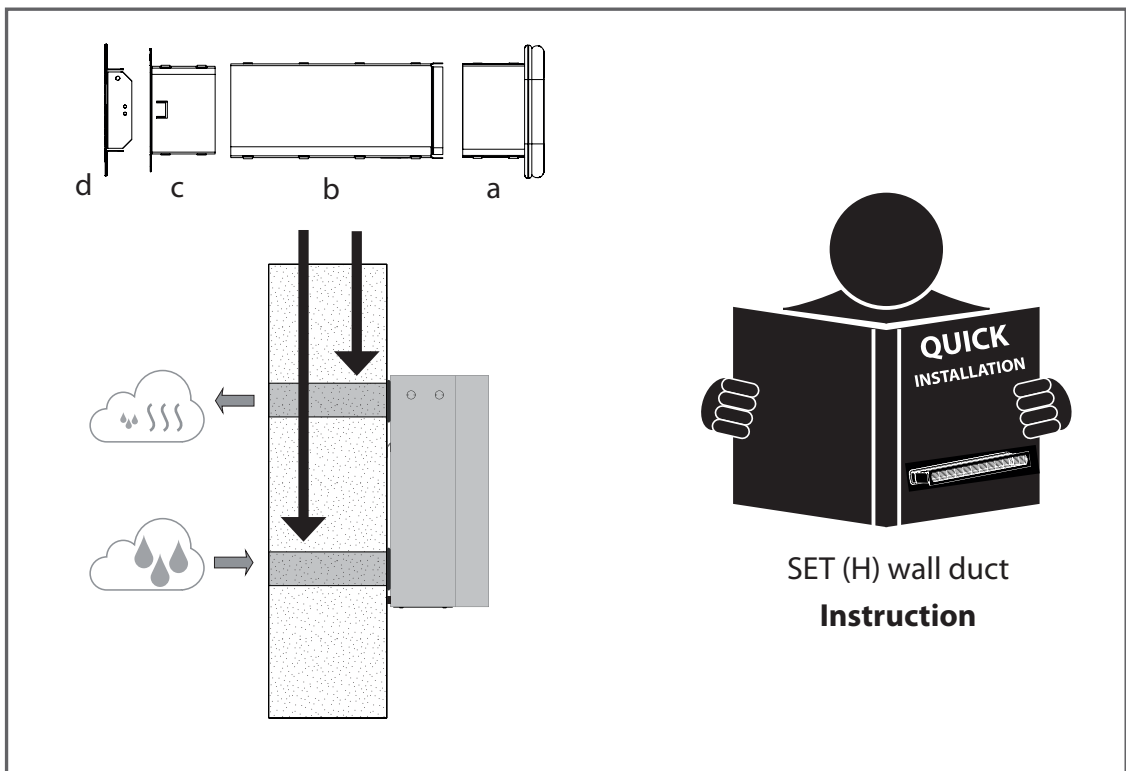

SET (H)

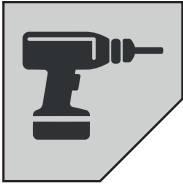

3

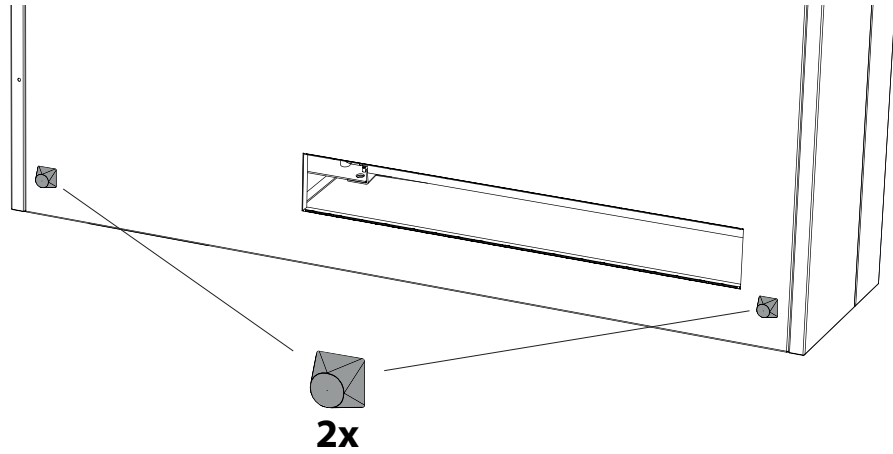

4

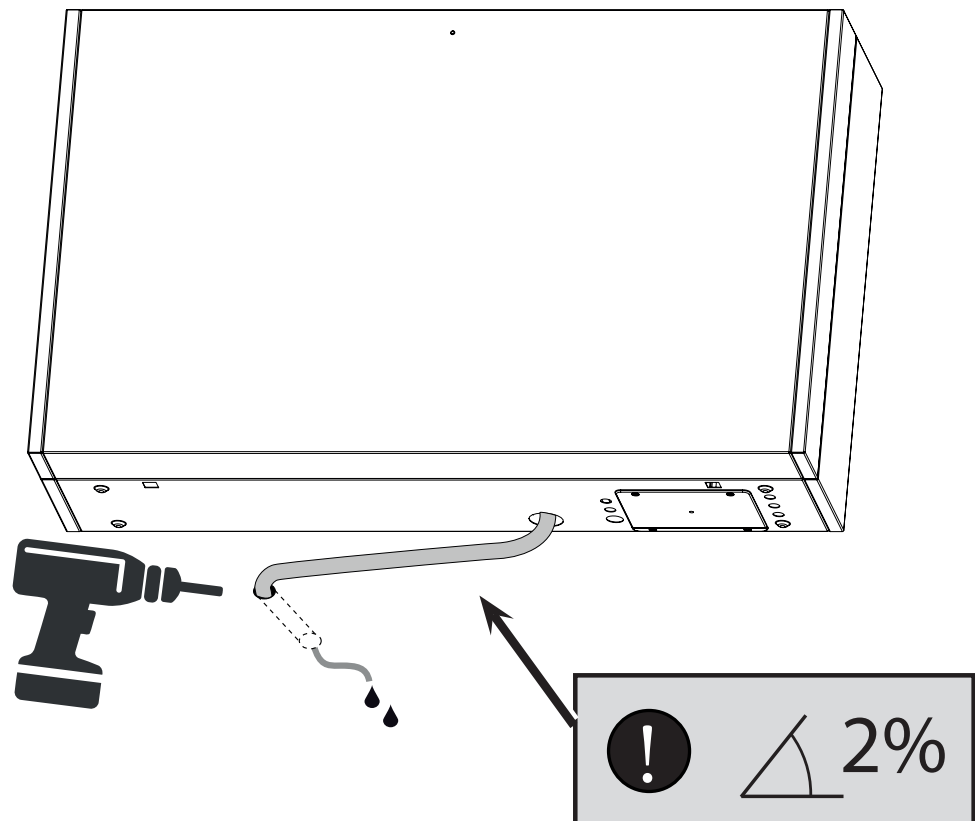

SET (H)

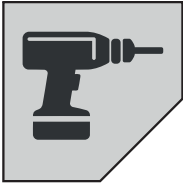

5

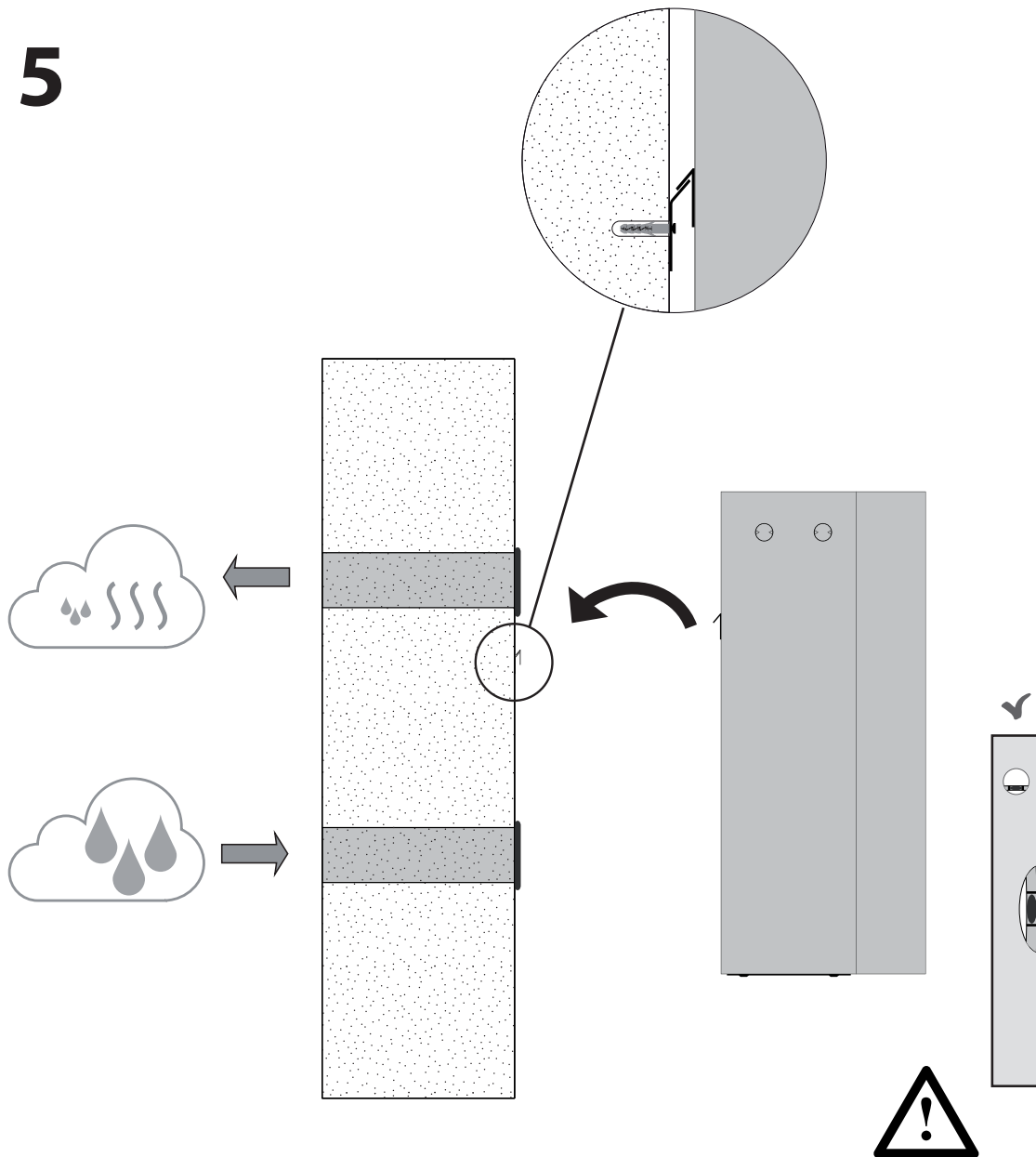

SET (T) + SET (H)

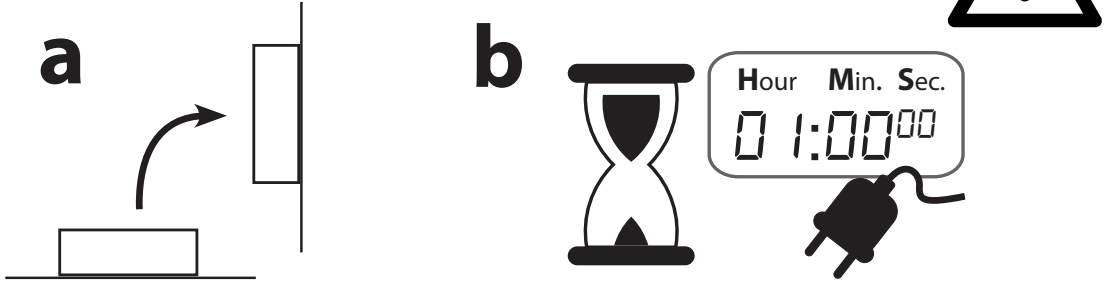
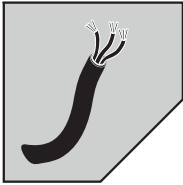

6

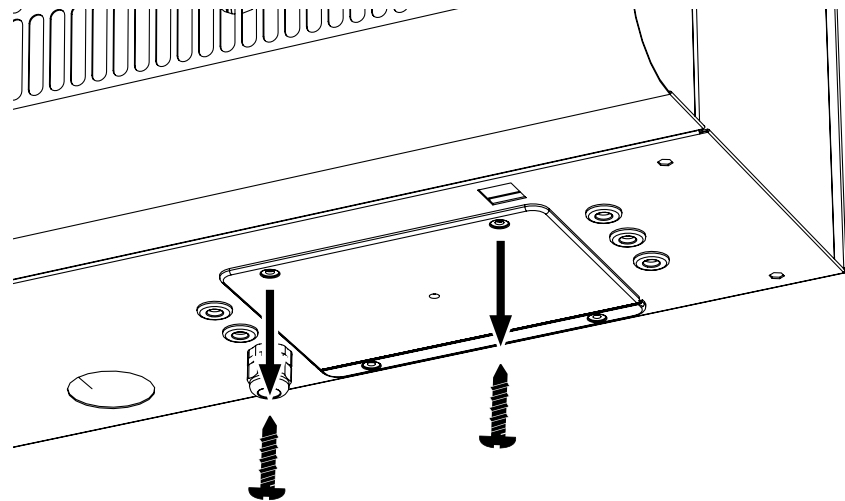

7

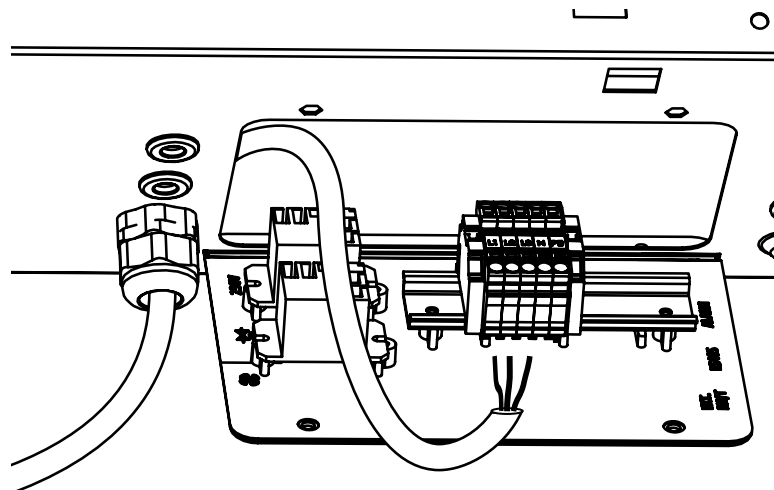

SET (T) + SET (H)

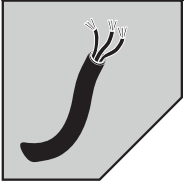

8

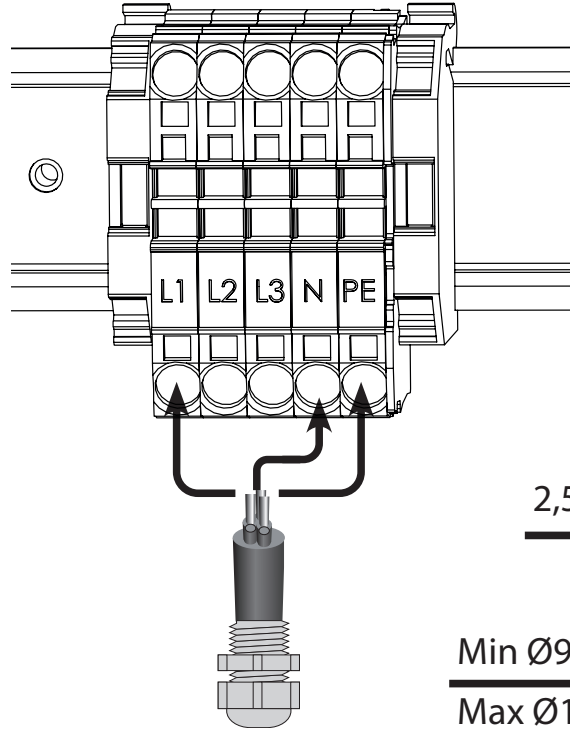
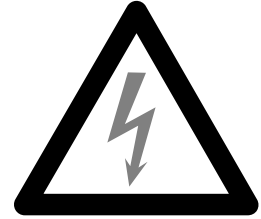

9

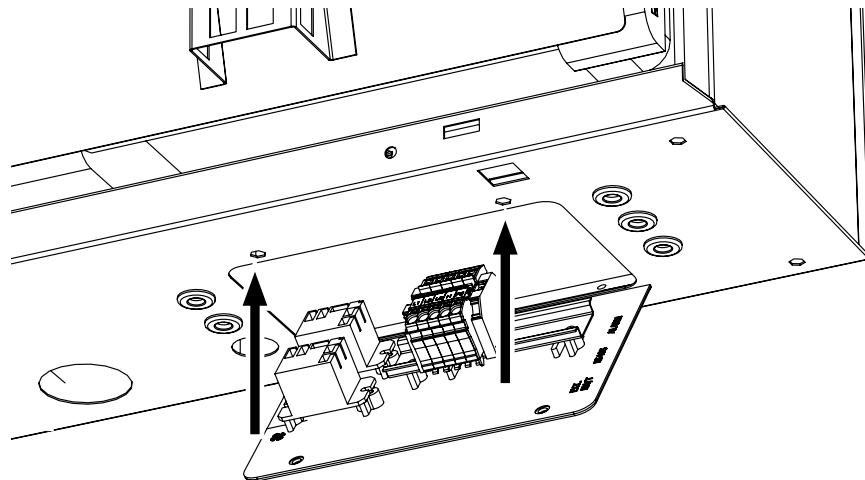

SET (T) + SET (H)

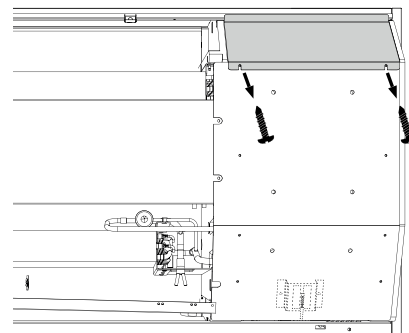
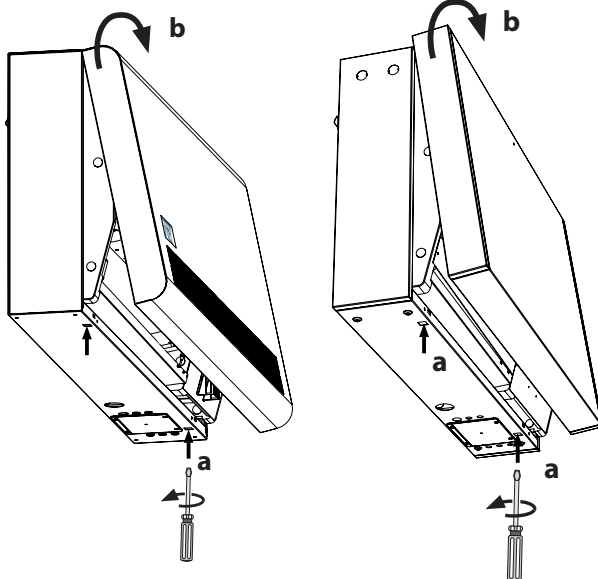
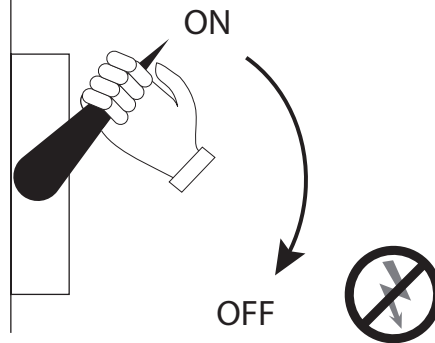
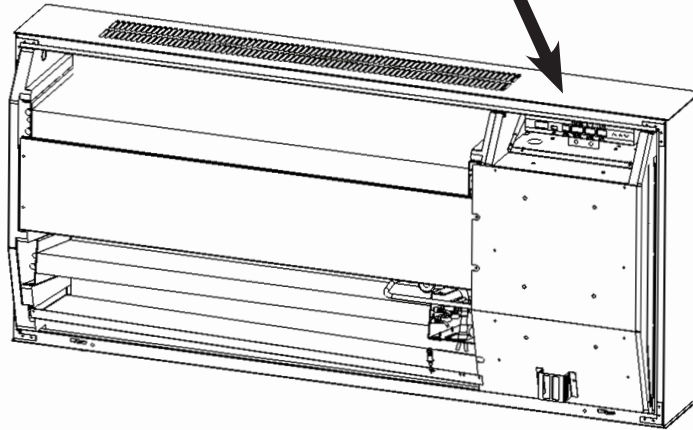
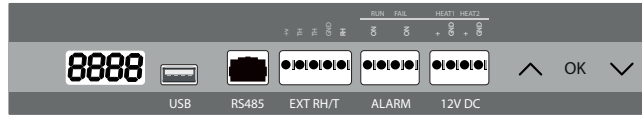

SET (T) + SET (H)

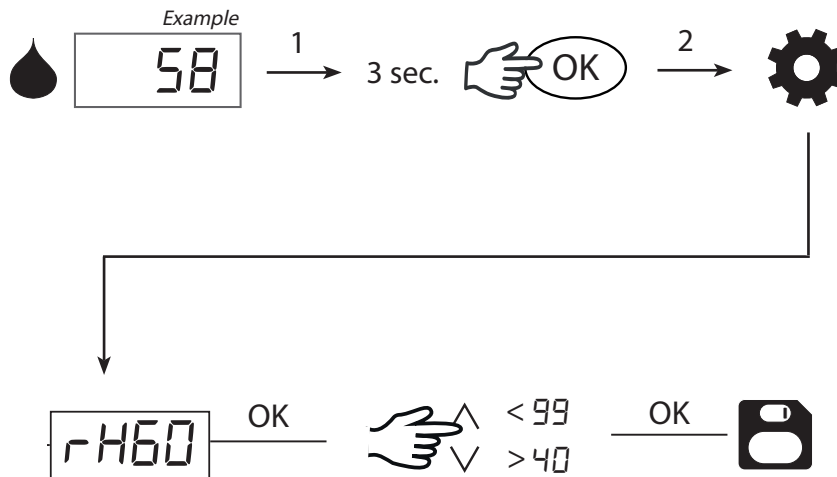
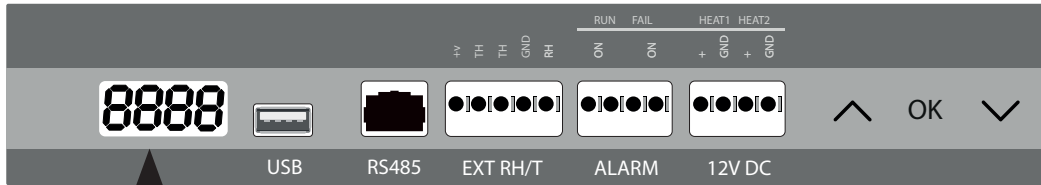



SET Energietechnik GmbH
A.-Blessing-Str. 5
DE-71282 Hemmingen

Tel. +49 (0) 71 50 – 94 54 10

Fax +49 (0) 71 50 – 23 37

www.set-energietechnik.de

info@set-energietechnik.de



109320

SET Energietechnik GmbH can accept no responsibility for possible errors and changes (en)

Irrtümer und Änderungen vorbehalten (de)

SET Energietechnik GmbH n'assume aucune responsabilité pour erreurs et modifications éventuelles (fr)

